

Block Dimensions

Classic™ 8

General Information

Absorption: Meets or exceeds ASTM 1372 standards

Compressive strength: ≥ 3000 PSI Approximate average minimum per ASTM 1372 (unless otherwise specified)

Unit Information

Beveled Classic Unit: 8"H X 18"W X 12"D, 79 Lbs. Approx. 1.00 Sq. Ft. Face

Straight Classic Unit: 8"H X 18"W X 12"D, 85 Lbs. Approx. 1.00 Sq. Ft. Face

Universal Cap: 4"H X 18"W Front and 4"H X 14"W Back, 54 Lbs. Approx. average running length is 16".

Face Options

- Face Patterns: Beveled Split Face
- Straight Split Face
- Colonial (available in certain markets)

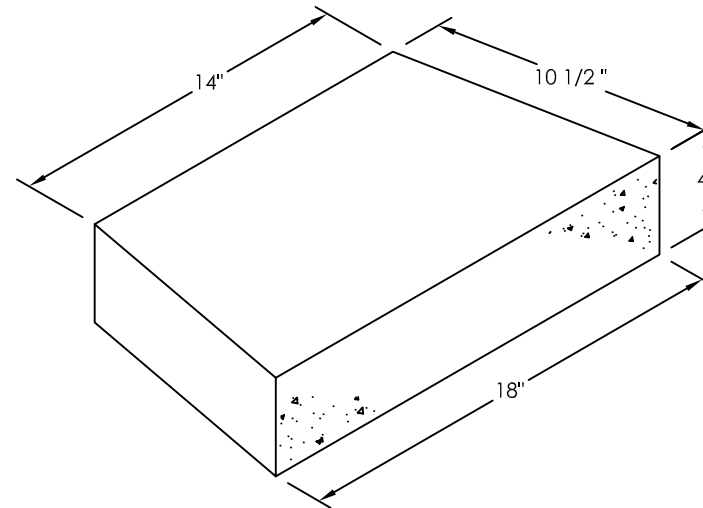

Universal Cap - front

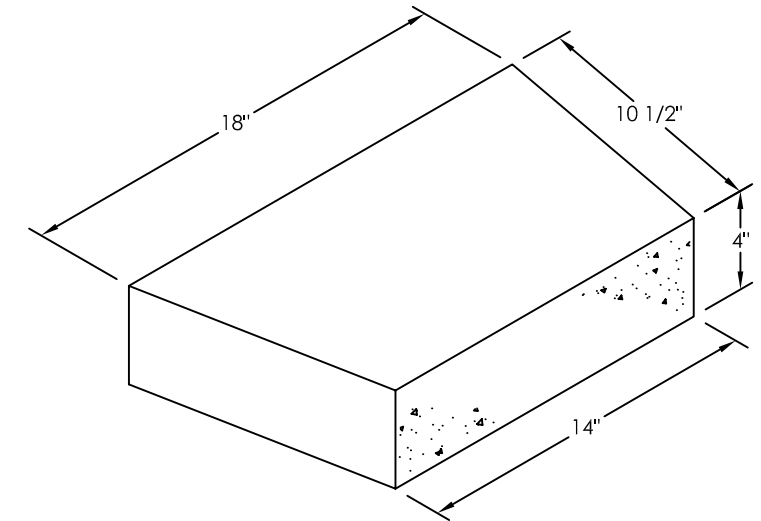

Universal Cap - Back

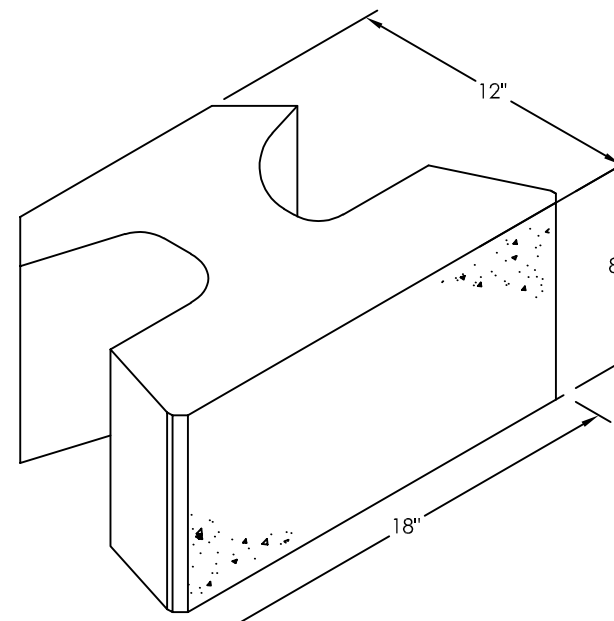

Classic 8 Unit (Straight)

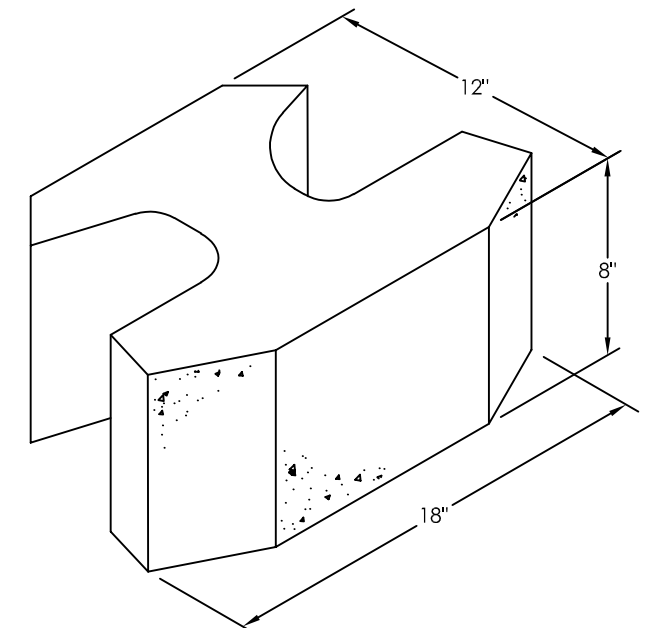

Classic 8 Unit (Beveled)

Not to Scale

This drawing is furnished for preliminary design purposes only, and should not be used for final design drawings or construction drawings without the certification of a professional engineer registered in the state in which the wall will be constructed. These drawings are "typical" and may be amended or revised by the SRW engineer based on project site conditions and purposes.

No.	Date.	Revision.	By.

PREPARED BY:

Legend

- Leveling Pad
- Drainage Rock
- Geogrid
- Finish Grade
- Filter Fabric
- Grid/Fabric Length (Measured from face of wall)

Project Name: _____

Project Location: _____

Drawing Description: **Classic 8 Block Dimensions**

Prepared For: _____

Drawn By: _____

Checked By: _____

Sheet: _____

Date: _____

Project Number: _____

Block Dimensions

Classic™ 6

General Information

Absorption: Meets or exceeds ASTM 1372 standards.

Compressive strength: ≥ 3000 PSI Approximate average minimum per ASTM 1372 (unless otherwise specified)

Unit Information

Beveled Classic Unit: 6"H X 18"W X 12"D, 60 Lbs. Approx. 0.75 Sq. Ft. Face

Straight Classic Unit: 6"H X 18"W X 12"D, 64 Lbs. Approx. 0.75 Sq. Ft. Face

Universal Cap: 4"H X 18"W Front and 4"H X 14"W Back, 54 Lbs. Approx. average running length is 16".

Face Options

Face patterns: Beveled Split Face
 Straight Split Face
 Colonial (available in certain markets)

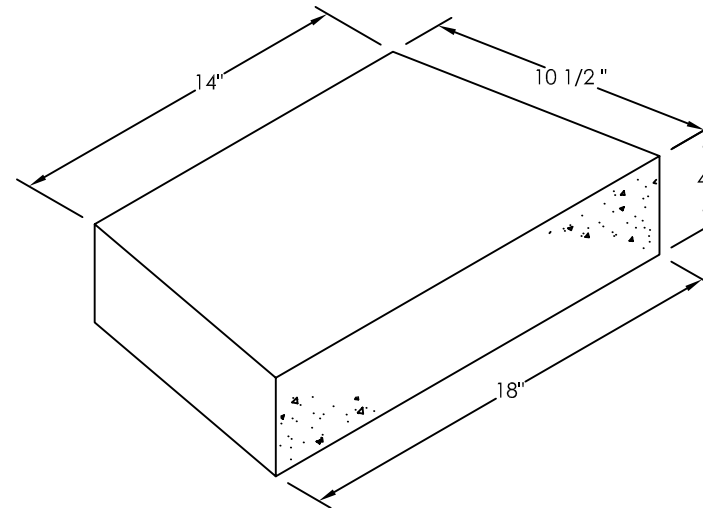

Universal Cap - front

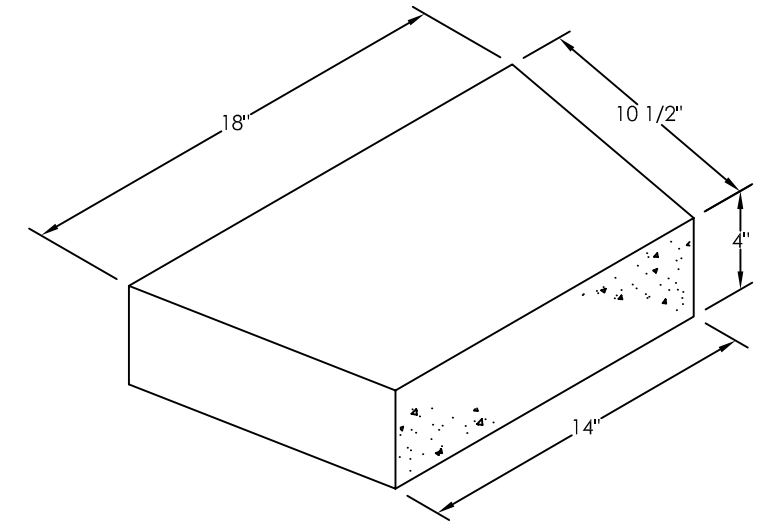

Universal Cap - Back

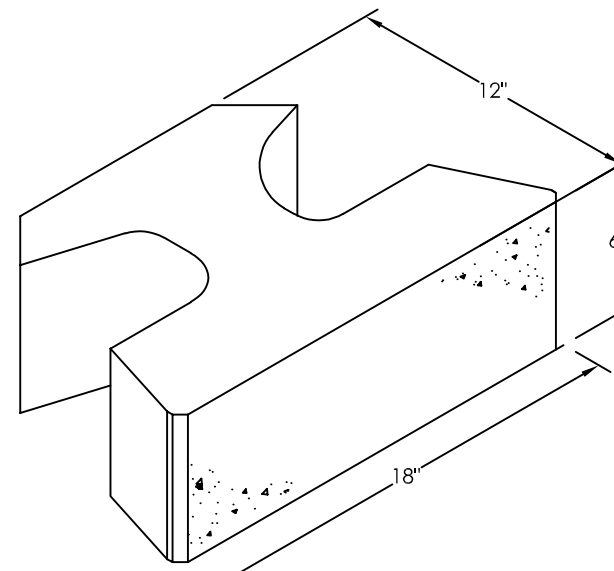

Classic 6 Unit (Straight)

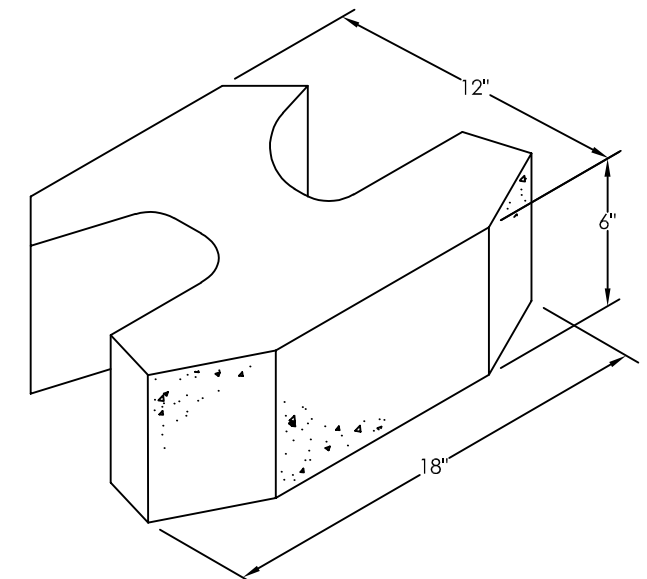

Classic 6 Unit (Beveled)

Not to Scale

This drawing is furnished for preliminary design purposes only, and should not be used for final design drawings or construction drawings without the certification of a professional engineer registered in the state in which the wall will be constructed. These drawings are "typical" and may be amended or revised by the SRW engineer based on project site conditions and purposes.

No.	Date.	Revision.	By.

PREPARED BY:

Legend

- Leveling Pad
- Drainage Rock
- Geogrid
- Finish Grade
- Filter Fabric
- Grid/Fabric Length (Measured from face of wall)

Project Name: _____

Project Location: _____

Drawing Description: **Classic 6 Block Dimensions**

Prepared For: _____

Drawn By: _____

Checked By: _____

Sheet: _____

Date: _____

Project Number: _____

Block Dimensions

Classic™ Colonial 6

General Information

Absorption: Meets or exceeds ASTM 1372 standards.

Compressive strength: ≥ 3000 PSI Approximate average minimum per ASTM 1372 (unless otherwise specified)

Unit Information

Colonial 6/12 Unit: 6" H X 12"W and 6" H X 6"W X 12"D, 64 lbs. Approx. 0.75 Sq. Ft. Face

Colonial 18 Unit: 6" H X 18"W X 12"D, 64 lbs. Approx. 0.75 Sq. Ft. Face

Universal Cap: 4"H X 18"W Front and 4"H X 14"W Back, 54 Lbs. Approx. average running length is 16'.

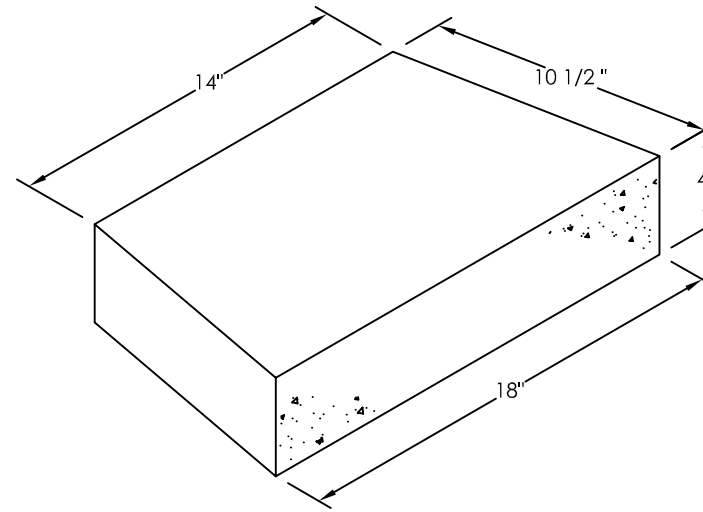

Universal Cap - front

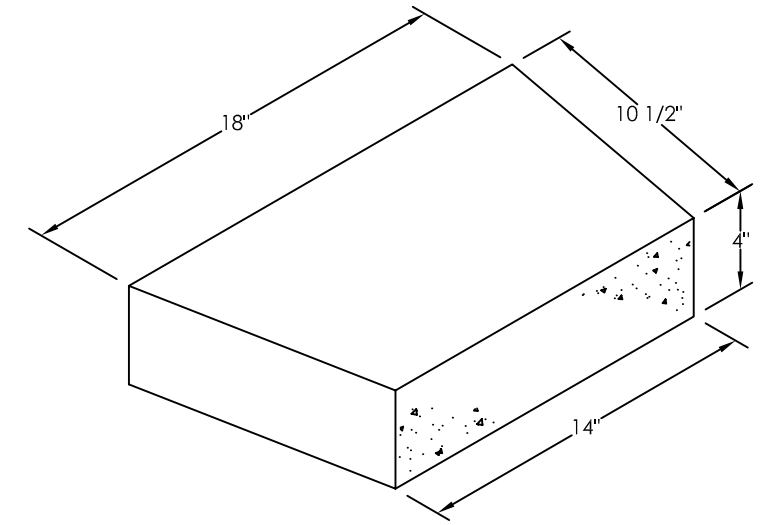

Universal Cap - Back

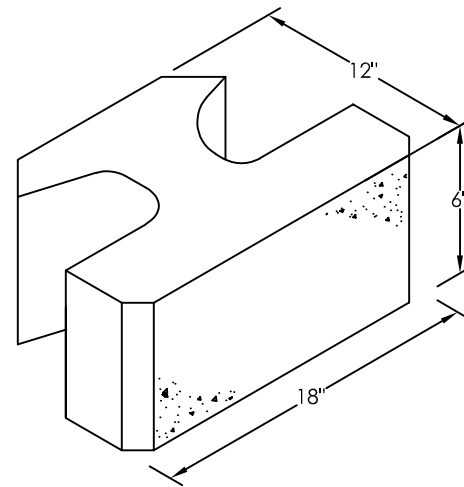

Classic 6 Colonial (18 Unit)

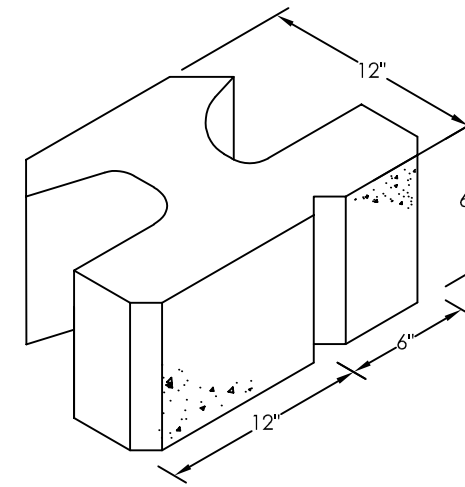

Classic 6 Colonial (12/6 Unit)

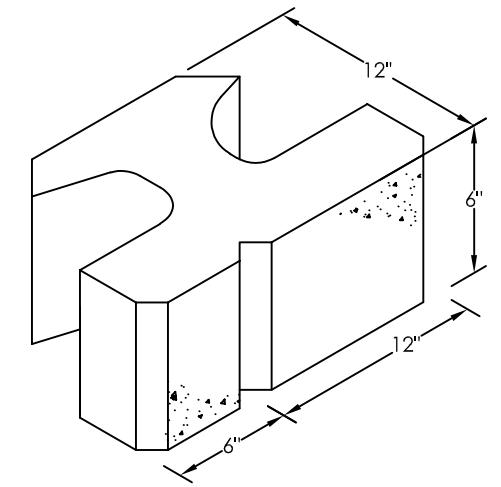

Classic 6 Colonial (6/12 Unit)

Not to Scale

This drawing is furnished for preliminary design purposes only, and should not be used for final design drawings or construction drawings without the certification of a professional engineer registered in the state in which the wall will be constructed. These drawings are "typical" and may be amended or revised by the SRW engineer based on project site conditions and purposes.

No.	Date.	Revision.	By.

PREPARED BY:

Legend

- Leveling Pad
- Drainage Rock
- Geogrid
- Finish Grade
- Filter Fabric
- Grid/Fabric Length (Measured from face of wall)

Project Name: _____

Project Location: _____

Drawing Description: **Classic Colonial Block Dimensions**

Prepared For: _____

Drawn By: _____

Checked By: _____

Sheet: _____

Date: _____

Project Number: _____

Block Dimensions

Classic™ Colonial 8

General Information

Absorption: Meets or exceeds ASTM 1372 standards.

Compressive strength: ≥ 3000 PSI Approximate average minimum per ASTM 1372 (unless otherwise specified)

Unit Information

Colonial 6/12 Unit: 8"H X 12"W and 8"H X 6"W X 12"D, 85 lbs. Approx. 0.75 Sq. Ft. Face

Colonial 18 Unit: 8"H X 18"W X 12"D, 85 lbs. Approx. 0.75 Sq. Ft. Face

Universal Cap: 4"H X 18"W Front and 4"H X 14"W Back, 54 Lbs. Approx. average running length is 16'.

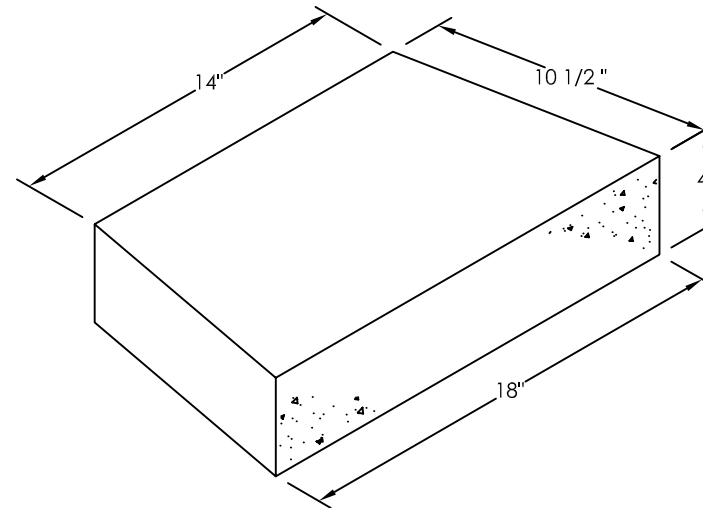

Universal Cap - front

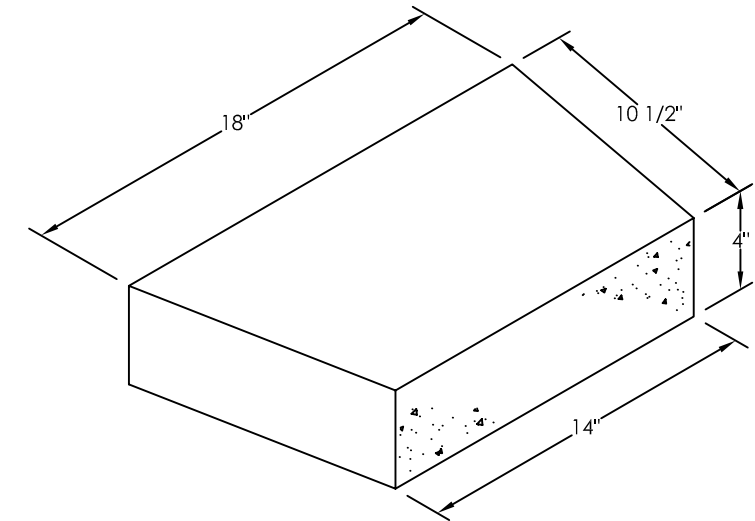

Universal Cap - Back

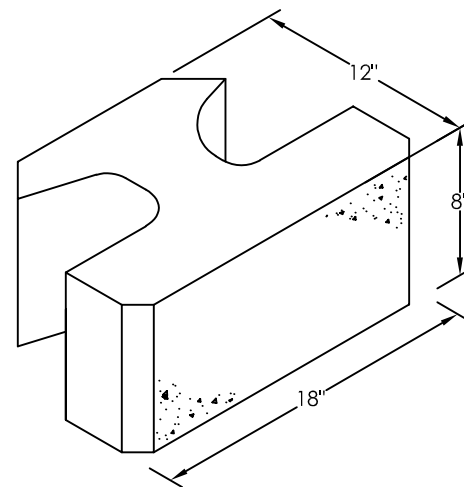

Classic 8 Colonial (18 Unit)

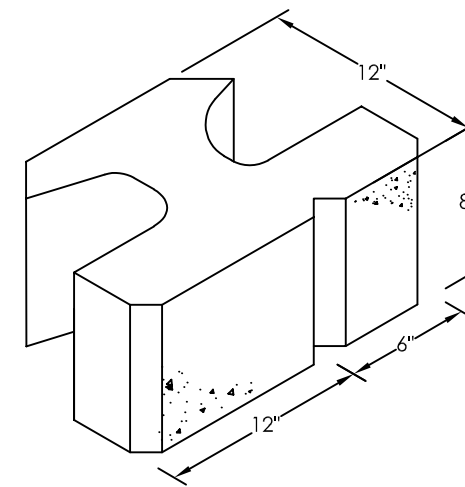

Classic 8 Colonial (12/6 Unit)

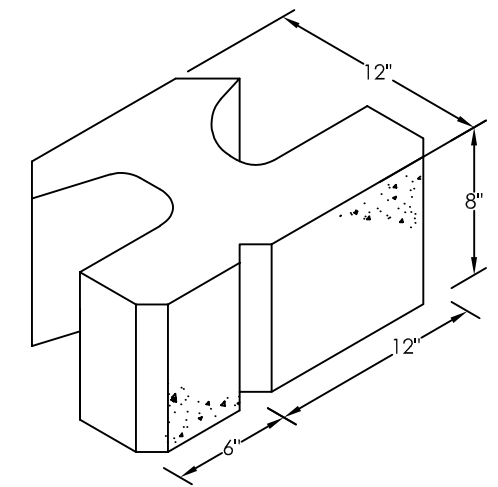

Classic 8 Colonial (6/12 Unit)

Not to Scale

This drawing is furnished for preliminary design purposes only, and should not be used for final design drawings or construction drawings without the certification of a professional engineer registered in the state in which the wall will be constructed. These drawings are "typical" and may be amended or revised by the SRW engineer based on project site conditions and purposes.

No.	Date.	Revision.	By.

PREPARED BY:

Legend

- Leveling Pad
- Drainage Rock
- Geogrid
- Finish Grade
- Filter Fabric
- Grid/Fabric Length (Measured from face of wall)

Project Name: _____

Project Location: _____

Drawing Description: **Classic Colonial Block Dimensions**

Prepared For: _____

Drawn By: _____

Checked By: _____

Sheet: _____

Date: _____

Project Number: _____

20" Classic™ Column

Classic™ (6, or 8)

Notes:

1. Classic™ straight face base block.
2. If regular Classic™ is used, anchor bar needs to be removed.
3. Adhere each course with a concrete adhesive, such as Super Stik®.
4. Split or saw tail of block off.

Classic block split face

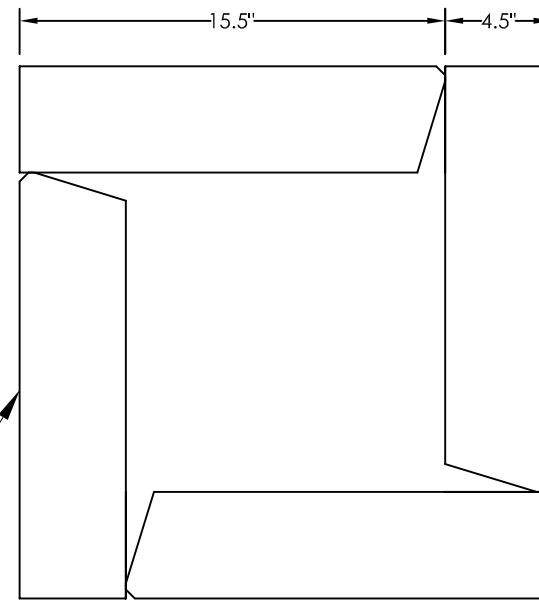

Odd course

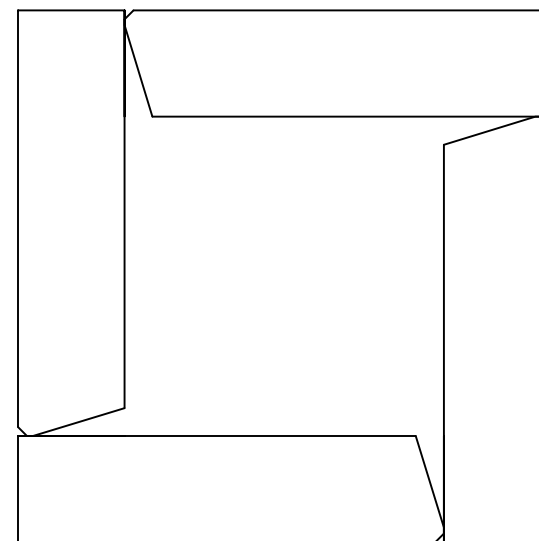
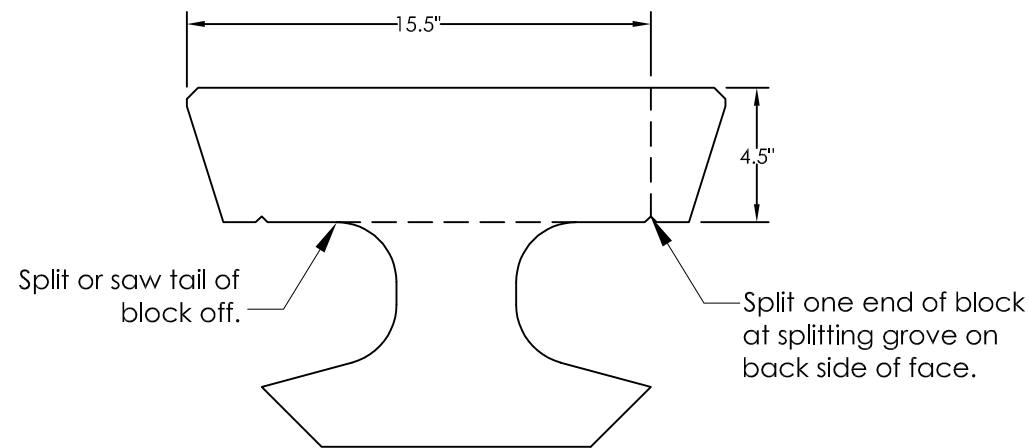
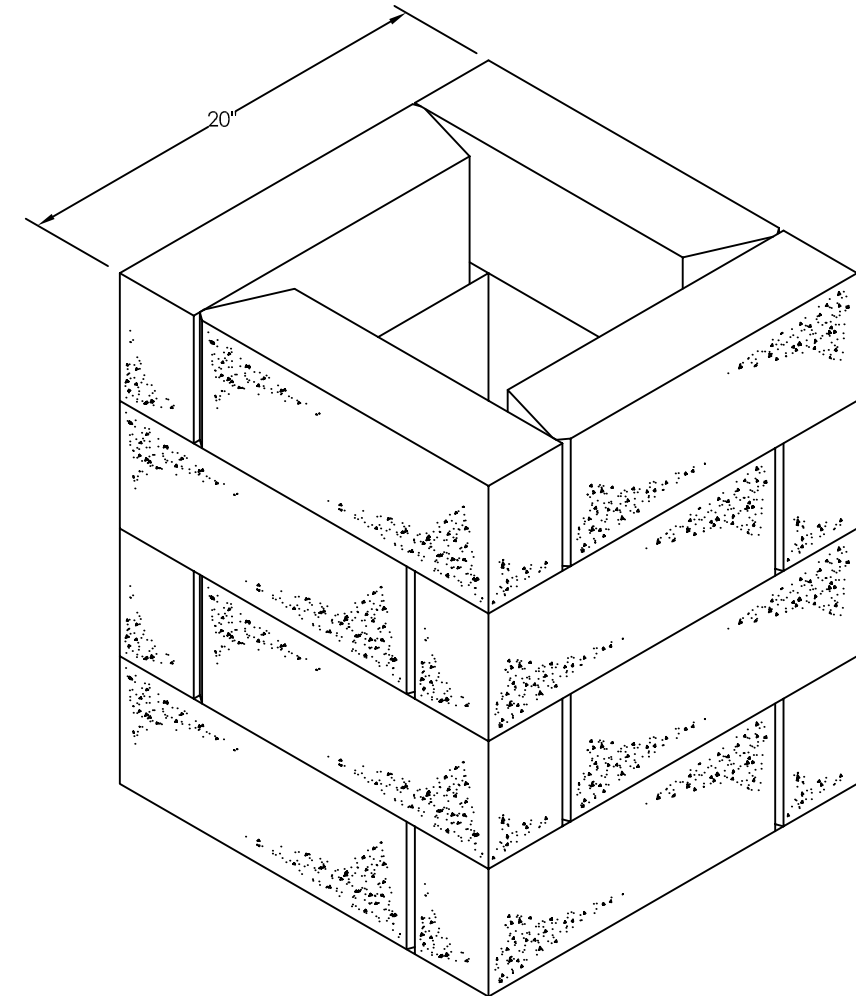

Even course

Not to Scale

This drawing is furnished for preliminary design purposes only, and should not be used for final design drawings or construction drawings without the certification of a professional engineer registered in the state in which the wall will be constructed. These drawings are "typical" and may be amended or revised by the SRW engineer based on project site conditions and purposes.

No.	Date.	Revision.	By.

PREPARED BY:

Legend

Project Name: _____

Project Location: _____

Drawing Description: **Classic 20" Column**

Prepared For: _____

Drawn By: _____ Checked By: _____

Sheet: _____

Date: _____

Project Number: _____

21" Classic™ Column

Classic™ (6, or 8)

Notes:

1. Classic™ straight face base block.
2. If regular Classic™ is used, anchor bar and stacking bar need to be removed.
3. Adhere each course with a concrete adhesive, such as Super Stik®.

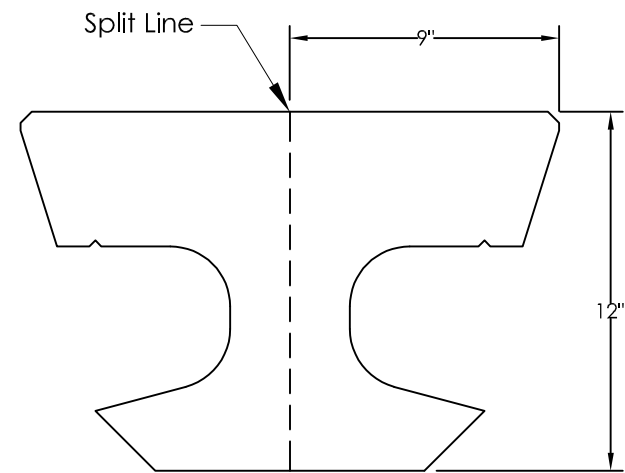

Classic block split face

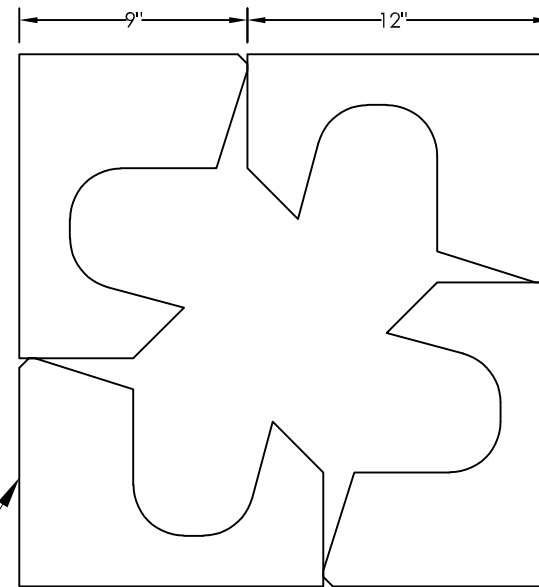

Odd course

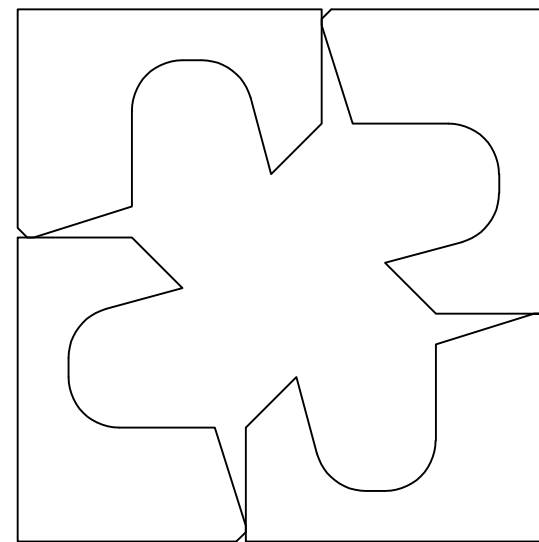

Even course

Not to Scale

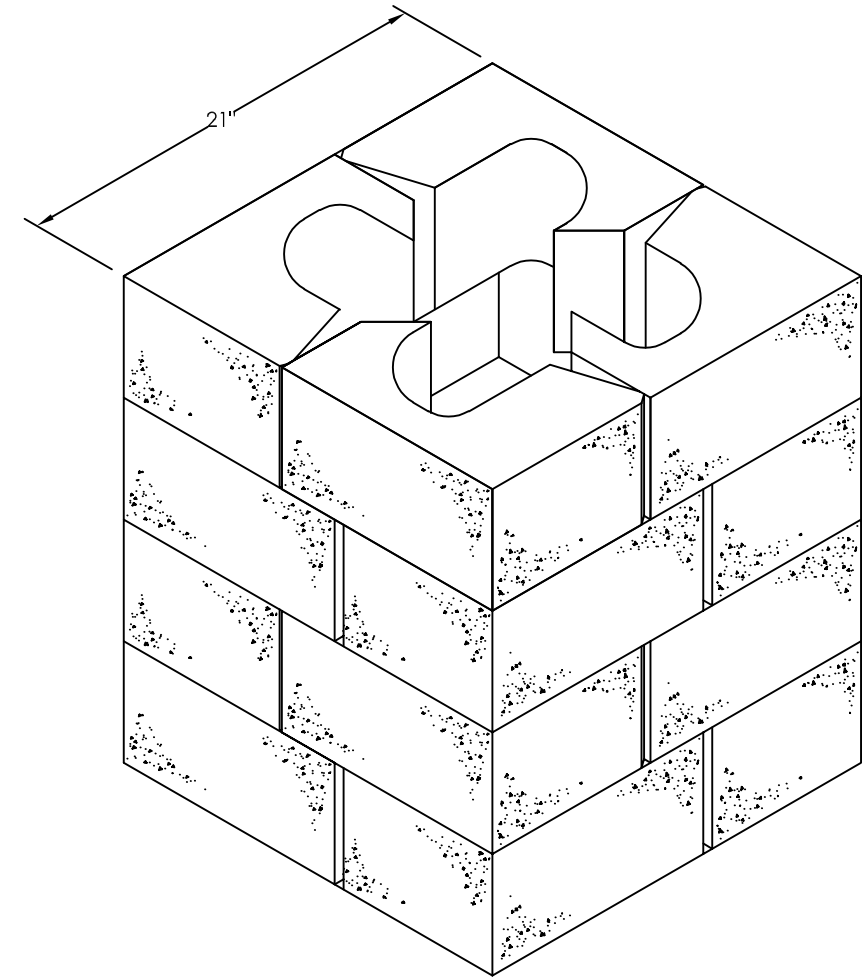

This drawing is furnished for preliminary design purposes only, and should not be used for final design drawings or construction drawings without the certification of a professional engineer registered in the state in which the wall will be constructed. These drawings are "typical" and may be amended or revised by the SRW engineer based on project site conditions and purposes.

No.	Date.	Revision.	By.

PREPARED BY:

ROCKWOOD
RETAINING WALLS
A better way.

Legend

Project Name: _____

Project Location: _____

Drawing Description: **Classic 21" Column**

Prepared For: _____

Drawn By: _____ Checked By: _____

Sheet: _____

Date: _____

Project Number: _____

Wall with Pipe Penetration

Rockwood Classic™

Notes:

1. Pipe to extend beyond base course of wall no less than 12"

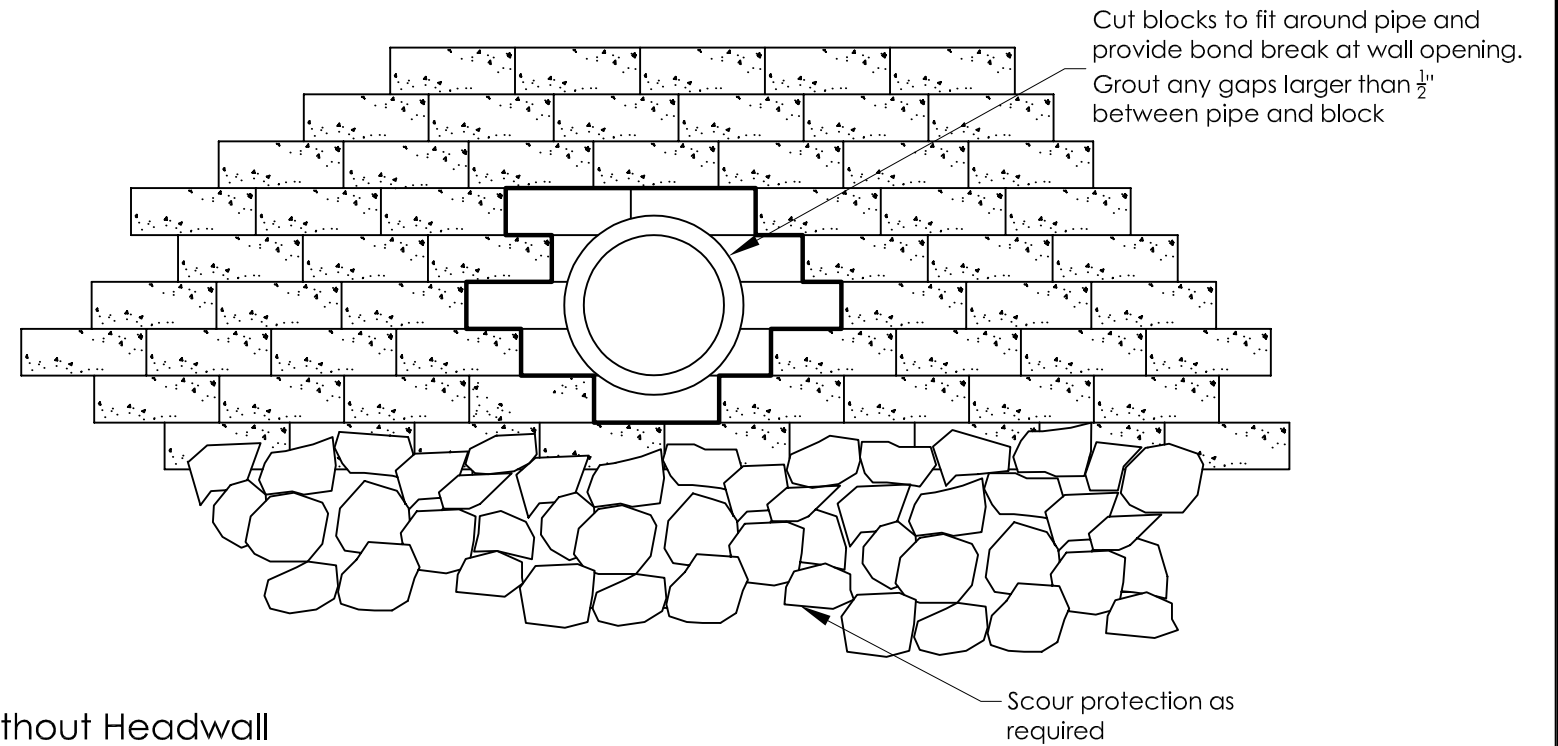
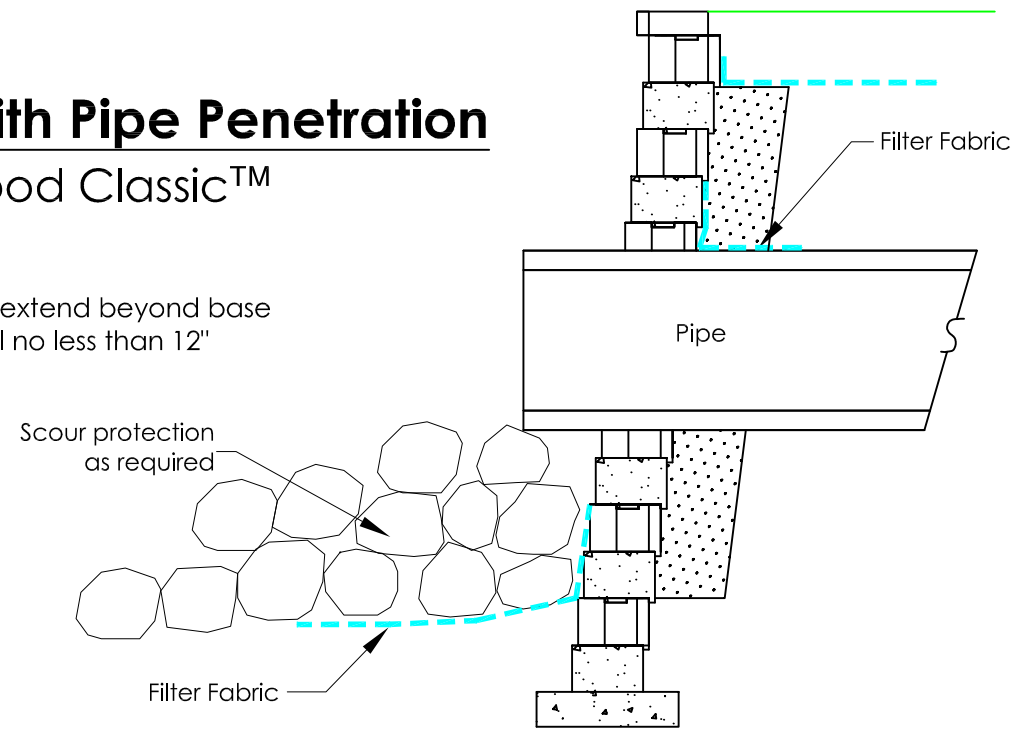

Pipe Penetration without Headwall

Grid removed for clarity
Not to Scale

Headwall should be sized to meet elevation coursing of Rockwood units for best results. Modifications to headwall with grout or grinding up to 1/2" are acceptable.

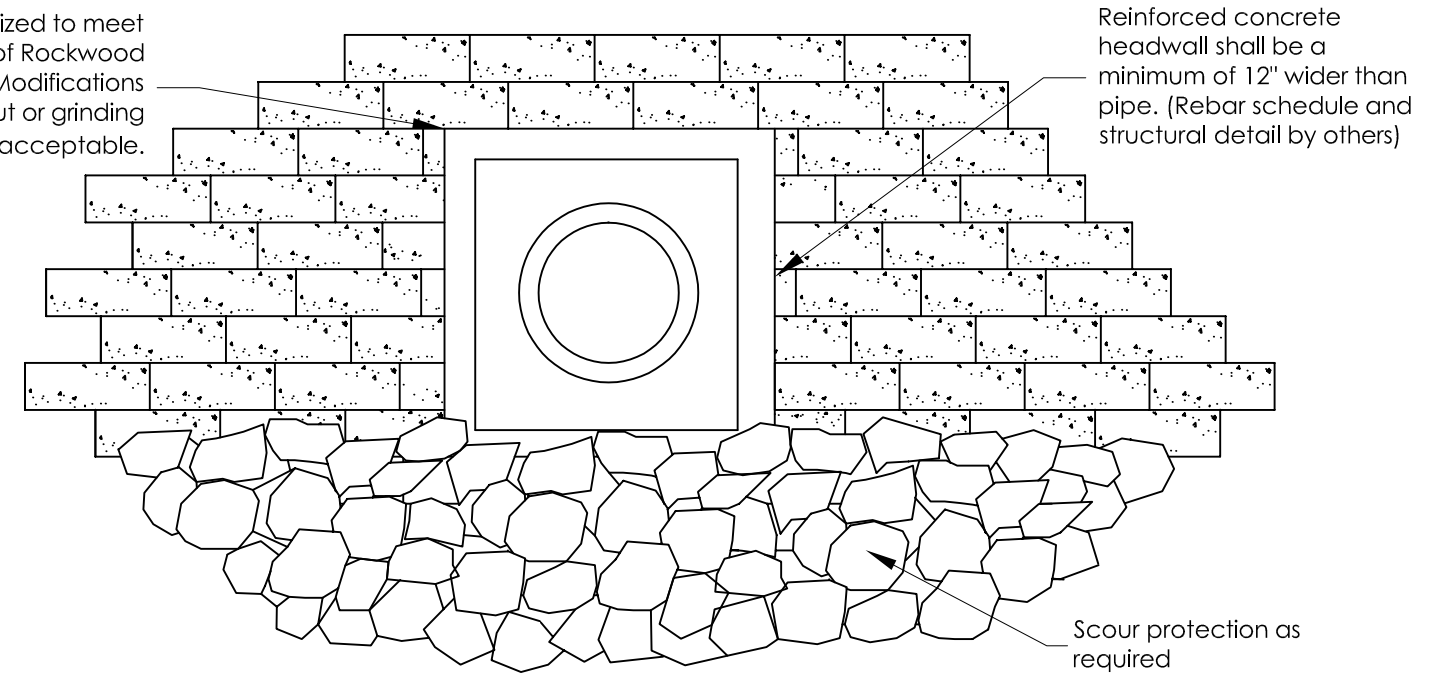
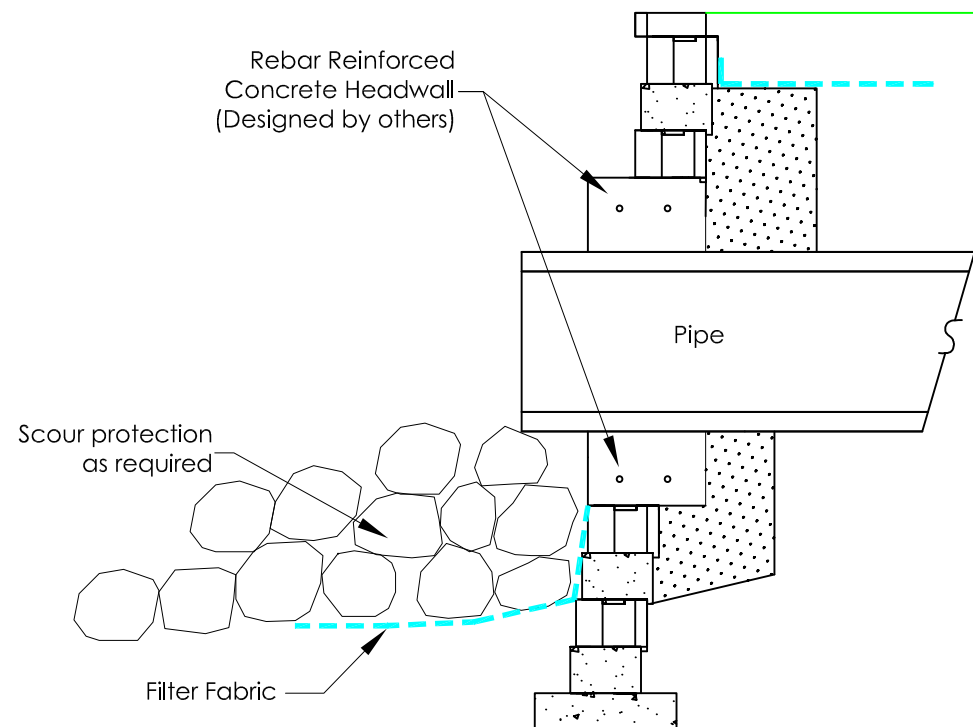

Pipe Penetration with Headwall

Grid removed for clarity
Not to Scale

This drawing is furnished for preliminary design purposes only, and should not be used for final design drawings or construction drawings without the certification of a professional engineer registered in the state in which the wall will be constructed. These drawings are "typical" and may be amended or revised by the SRW engineer based on project site conditions and purposes.

No.	Date.	Revision.	By.

PREPARED BY:

Legend	
	Leveling Pad
	Drainage Rock
	Geogrid
	Finish Grade
	Filter Fabric

Project Name: _____

Project Location: _____

Drawing Description: **Wall with Pipe Penetration**

Prepared For: _____

Drawn By: _____

Checked By: _____

Sheet: _____

Date: _____

Project Number: _____

Drain Tile Outlet Detail

Rockwood Classic™

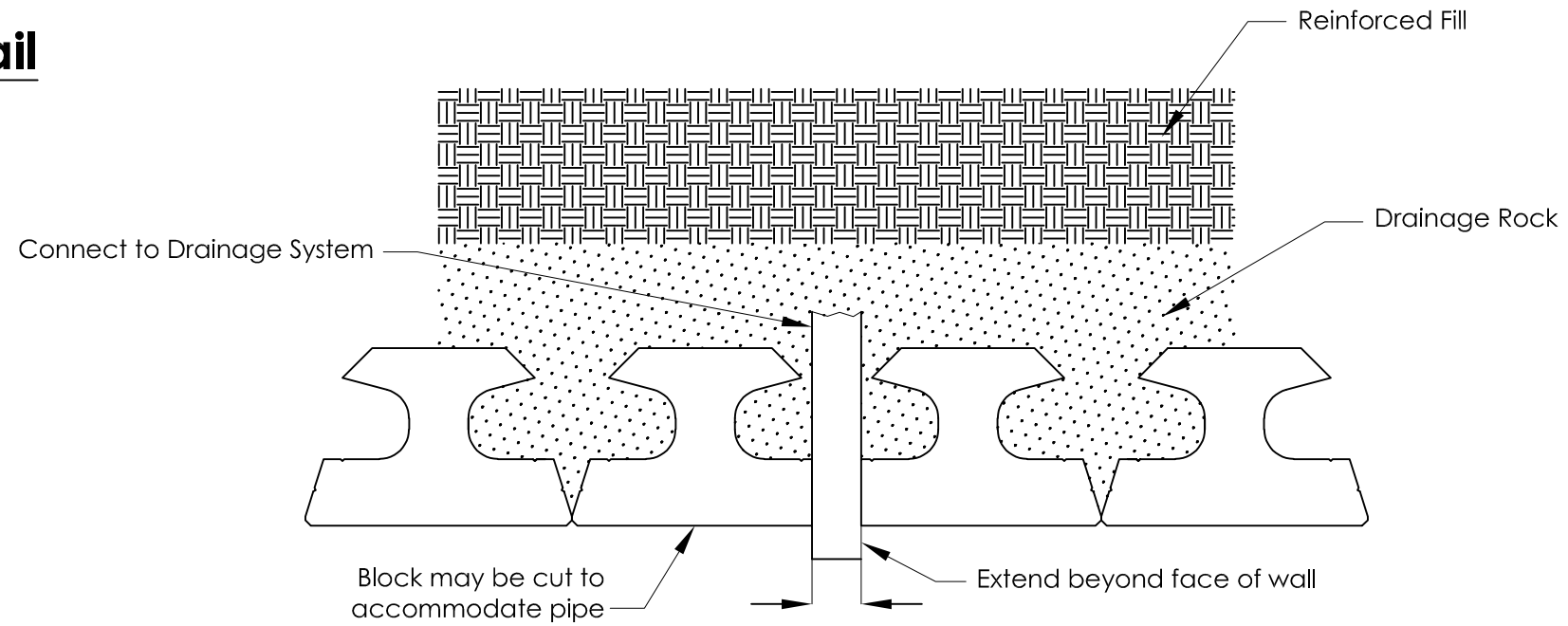

Drain Tile Outlet
 (At approximately 50ft intervals)
 Stub-out 4" drain pipe from heel drain through face or end of wall, to "daylight" or area drainage system at the lowest practical elevation. More than one outlet may be required if multiple low points exist along the length of the wall.

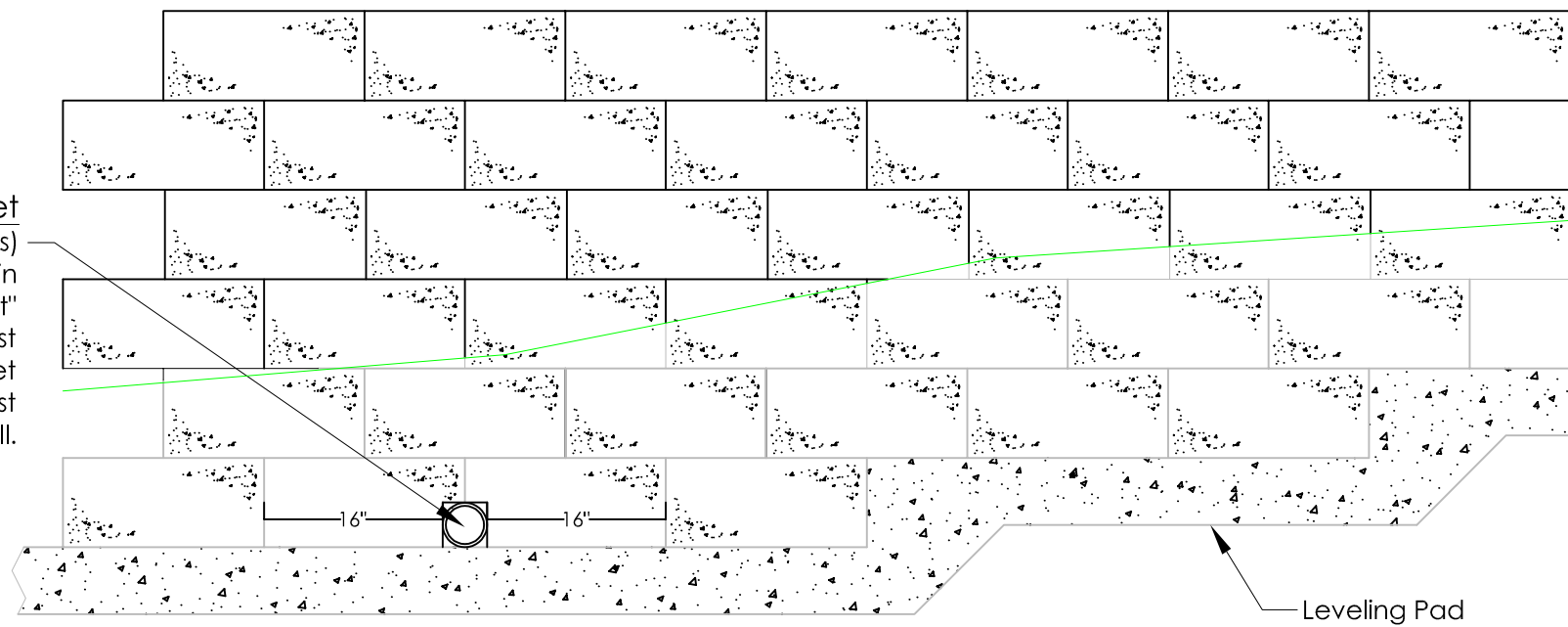

Not to Scale

This drawing is furnished for preliminary design purposes only, and should not be used for final design drawings or construction drawings without the certification of a professional engineer registered in the state in which the wall will be constructed. These drawings are "typical" and may be amended or revised by the SRW engineer based on project site conditions and purposes.

No.	Date.	Revision.	By.

PREPARED BY:

Legend	
	Leveling Pad
	Drainage Rock
	Geogrid
	Finish Grade
	Filter Fabric

Project Name:	Prepared For:
Project Location:	Drawn By: Checked By:
	Sheet:
Drawing Description:	Date:
Drain Tile Outlet Detail	Project Number:

Drainage Options

Rockwood Classic™

Provide for drainage away from wall.
(i.e. Drainage Swale or Impermeable Soils.)

Provide for drainage away from wall.
(i.e. Drainage Swale or Impermeable Soils.)

Place a minimum of 12" of
drainage rock behind
block, where shown.

Place a minimum of 12" of
drainage rock behind
block, where shown.

Drain Tile (Conditional)

Provide outlet for draitile to
daylight every 50 linear ft.
and at low points.

J Drain or Wall Board tied
into heel drain TYP. 50%
coverage $\frac{2}{3}$ height
(conditional).

Heel Drain (Conditional)
Aprox 2 cf/ft of crushed rock
wrapped in filter fabric (not required
in areas where the combined wall
height is less than six courses)

Non-Perforated Pipe Outlet at lowest
possible elevation. Maintain 1% min. fall.
Add "T" Connectors and pipe to front
drain at wall low points and a min. of
every 50 linear ft.

Heel Drain Outlet
Stub-out 4" drain pipe from heel drain through face or end of
wall, to "daylight" or area drainage system at the lowest
practical elevation at a minimum of 50 ft intervals. More than
one outlet may be required if multiple low points exist along
the length of the wall.

Leveling Pad (6"D x 24"W)

DGA should be placed under
drainage tile to finished
grade elevation.

Drain Outlet
Stub-out 4" drain pipe from heel drain through face or end of
wall, to "daylight" or area drainage system at the lowest
practical elevation at a minimum of 50 ft intervals. More than
one outlet may be required if multiple low points exist along
the length of the wall.

Leveling Pad (6"D x 24"W)

DGA should be placed under
drainage tile to finished
grade elevation.

Typical Heel Drain Option

Typical J Drain/Wall Board Option

Not to Scale





This drawing is furnished for preliminary design purposes only, and should not be used for final design drawings or construction drawings without the certification of a professional engineer registered in the state in which the wall will be constructed. These drawings are "typical" and may be amended or revised by the SRW engineer based on project site conditions and purposes.

No.	Date.	Revision.	By.

PREPARED BY:

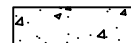
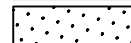

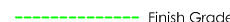
ROCKWOOD
RETAINING WALLS
A better way.

Legend	
	Leveling Pad
	Drainage Rock
	Geogrid
	Finish Grade
	Filter Fabric

Project Name:	
Project Location:	
Drawing Description:	Drainage Options

Prepared For:	
Drawn By:	
Checked By:	
Sheet:	
Date:	
Project Number:	

Fence Details

Rockwood Classic™

*Non Wind/Load Bearing Fence. If lateral loads will be applied, fence should be designed by a registered engineer.

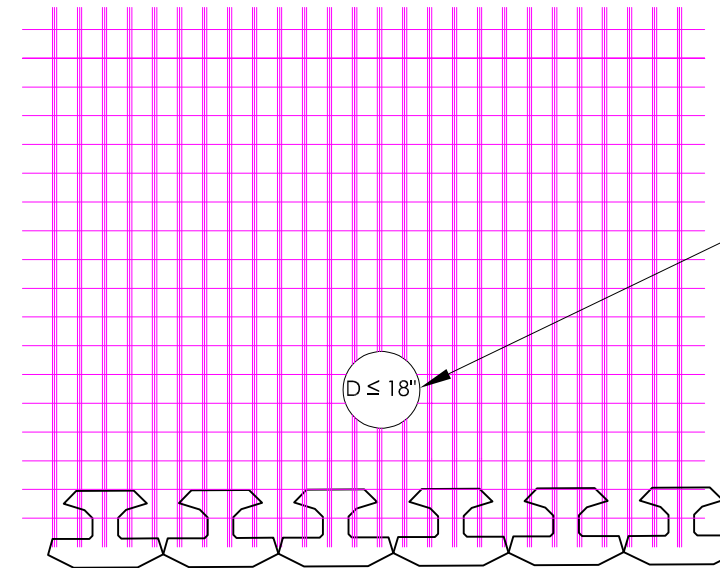

Install Sonotube or SLEEVE-IT.
Cut grid and wrap around sonotube or SLEEVE-IT. Grid may be bundled in vicinity of structure, then layered back out, as an alternate.

Note: Cut successive layers of Geogrid around proposed fence post or guardrail post installation points. Backfill and compact around Sonotube or SLEEVE-IT. Check fence design for embedment depth of fence post

Plan View

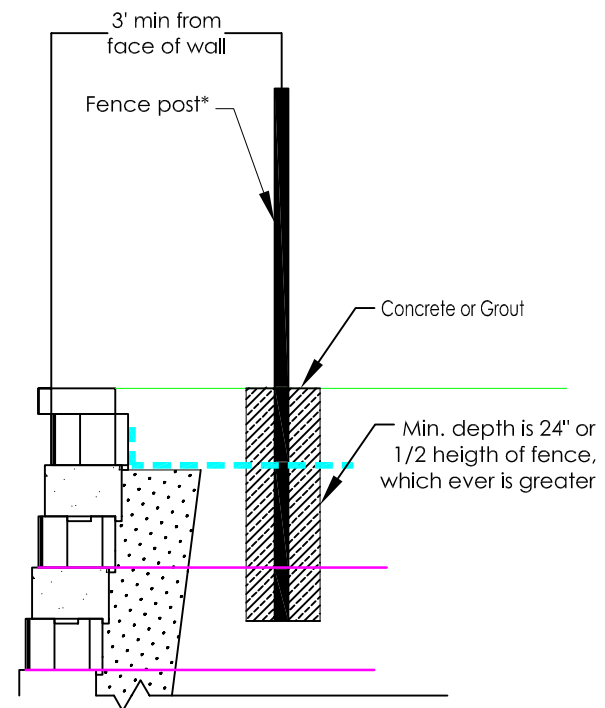

Fence Near Wall

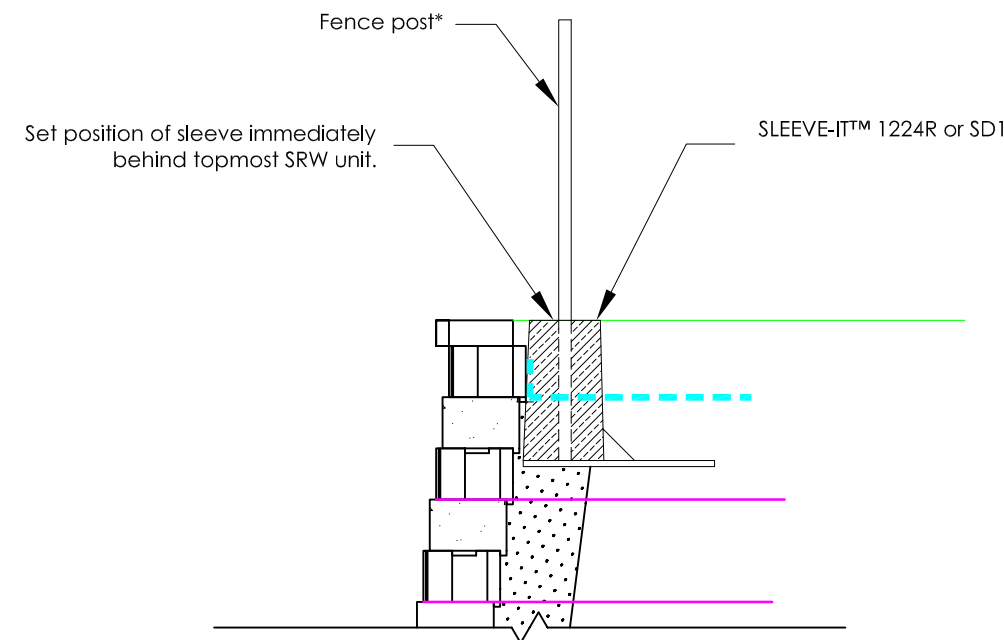

Fence with SLEEVE-IT

Not to Scale

This drawing is furnished for preliminary design purposes only, and should not be used for final design drawings or construction drawings without the certification of a professional engineer registered in the state in which the wall will be constructed. These drawings are "typical" and may be amended or revised by the SRW engineer based on project site conditions and purposes.

No.	Date.	Revision.	By.

PREPARED BY:

Legend	
	Leveling Pad
	Drainage Rock
	Geogrid
	Finish Grade
	Filter Fabric

Project Name:	Prepared For:
Project Location:	Drawn By: Checked By:
Drawing Description:	Sheet:
Fence Details	Date:
	Project Number:

Guard Rail Detail

Rockwood Classic™

If structure is less than 18" wide, cut grid around structure. Grid may be bundled in vicinity of structure, then layered back out.

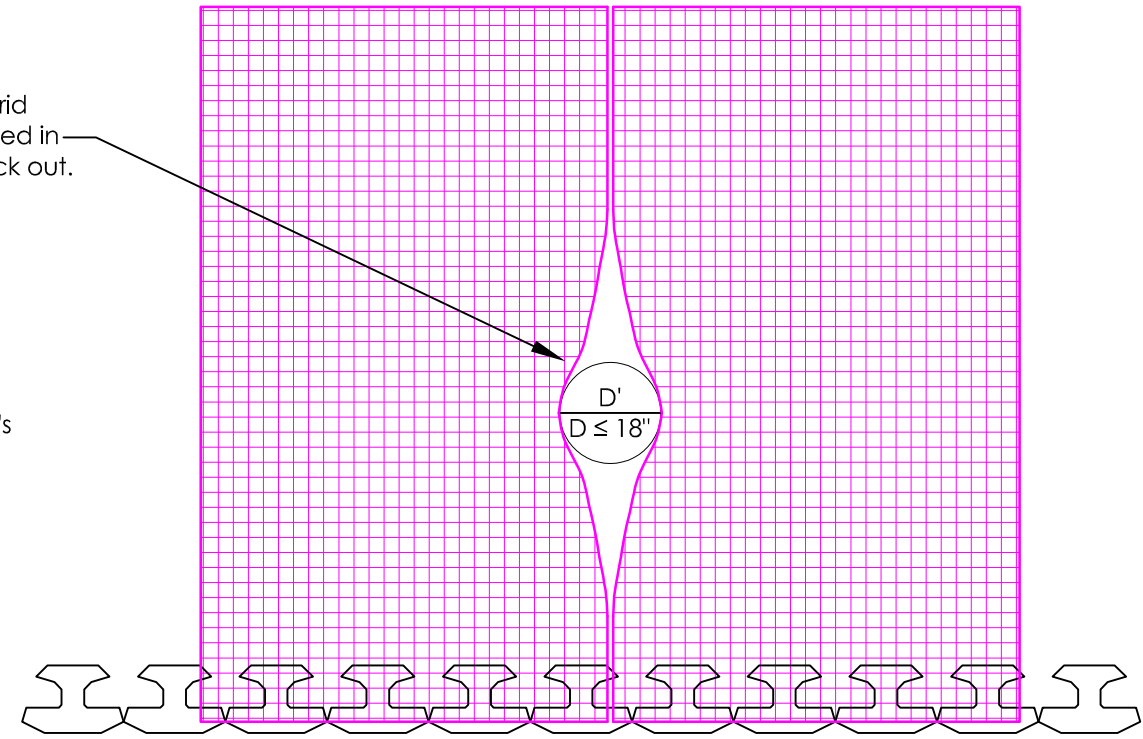
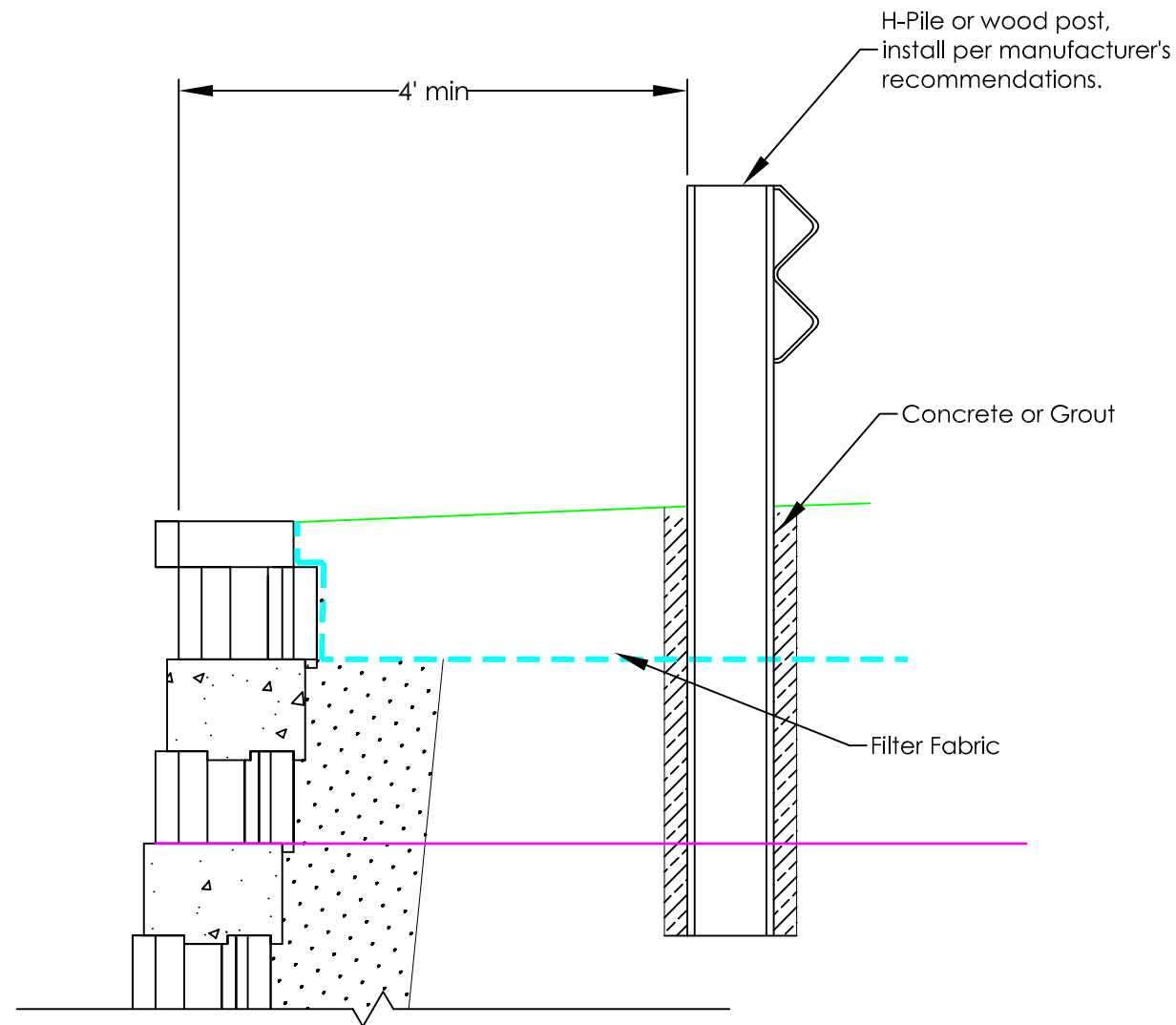

Consult a local engineer for guardrail embedment and setback from wall.

Not to Scale

This drawing is furnished for preliminary design purposes only, and should not be used for final design drawings or construction drawings without the certification of a professional engineer registered in the state in which the wall will be constructed. These drawings are "typical" and may be amended or revised by the SRW engineer based on project site conditions and purposes.

No.	Date.	Revision.	By.

PREPARED BY:

Legend	
	Leveling Pad
	Drainage Rock
	Geogrid
	Finish Grade
	Filter Fabric

Project Name:	
Project Location:	
Drawing Description:	Guard Rail Detail

Prepared For:	
Drawn By:	
Checked By:	
Sheet:	
Date:	
Project Number:	

Geogrid Details

Rockwood Classic™

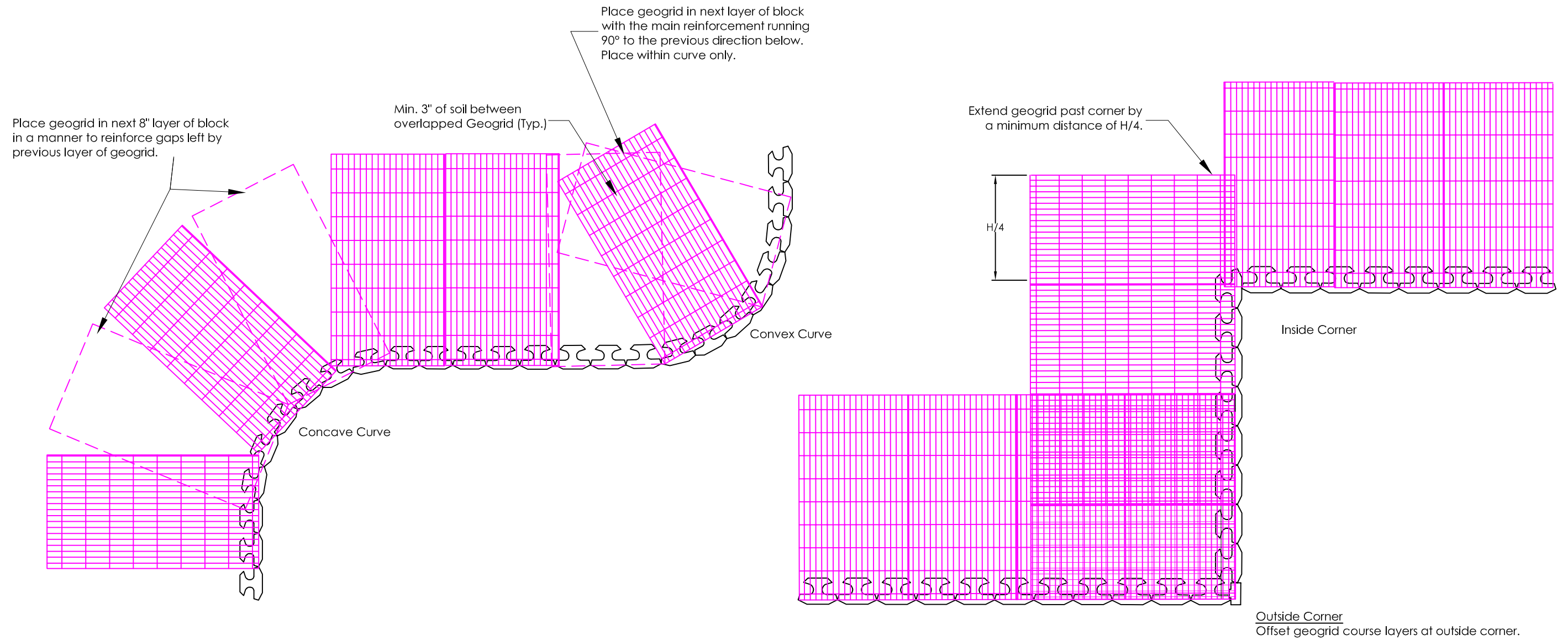

Not to Scale

This drawing is furnished for preliminary design purposes only, and should not be used for final design drawings or construction drawings without the certification of a professional engineer registered in the state in which the wall will be constructed. These drawings are "typical" and may be amended or revised by the SRW engineer based on project site conditions and purposes.

No.	Date.	Revision.	By.

PREPARED BY:

ROCKWOOD
RETAINING WALLS
A better way.™

Legend

Project Name:	Prepared For:
Project Location:	Drawn By: Checked By:
Drawing Description:	Sheet:
Geogrid Details	Date:
	Project Number:

Typical Details

Rockwood Classic™

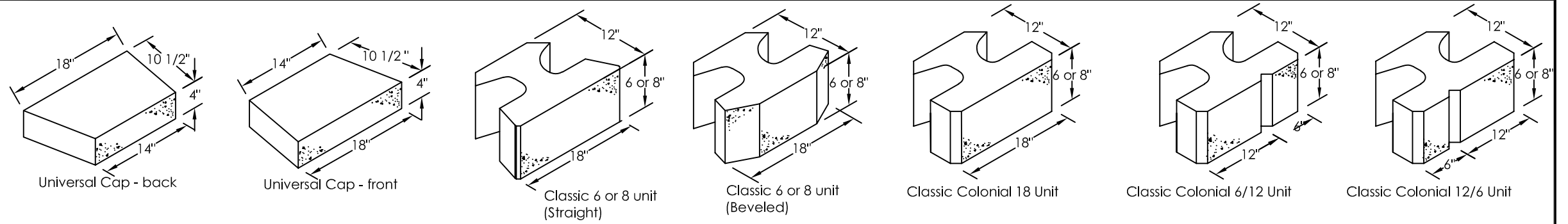

NCMA Minimum Embedment	
Slope in front of wall	Minimum H_{emb} to top of leveling pad
Horizontal (Walls)	H'/20
Horizontal (Abutments)	H'/10
3H:1V	H'/10
2H:1V	H'/7
Minimum embedment	6 in

Note: H' is the exposed height of the SRW. The bottom of the wall should not be above the finish grade elevation 4ft in front of the wall

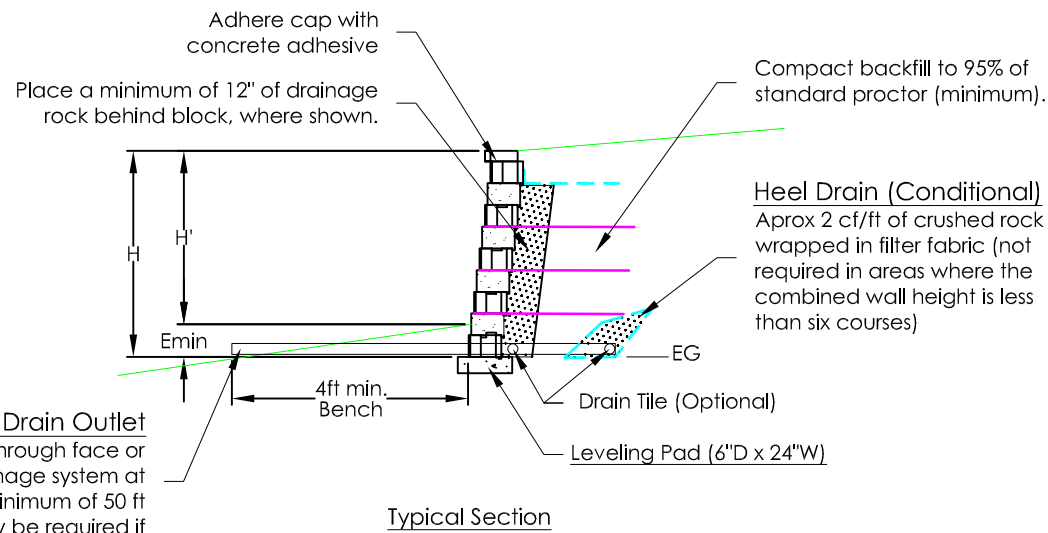

Heel Drain Outlet
Stub-out 4" drain pipe from heel drain through face or end of wall, to "daylight" or area drainage system at the lowest practical elevation at a minimum of 50 ft intervals. More than one outlet may be required if multiple low points exist along the length of the wall.

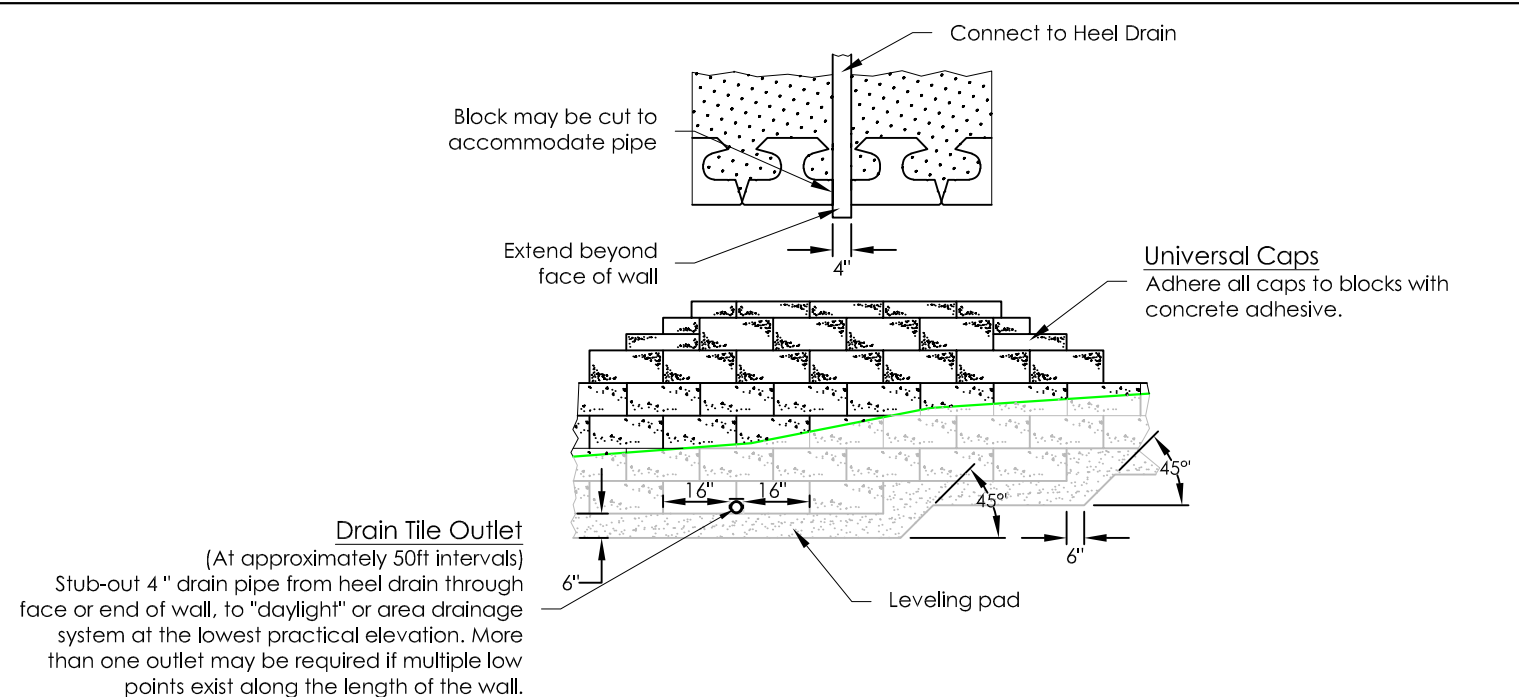
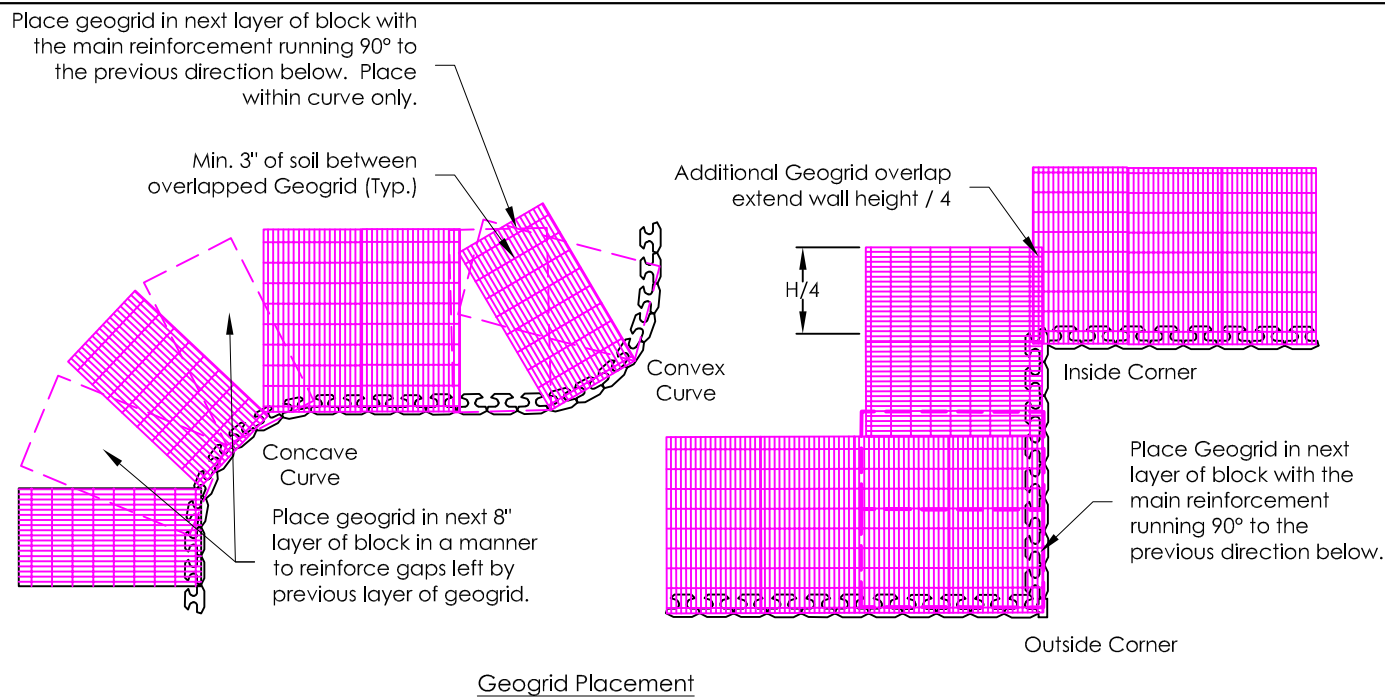
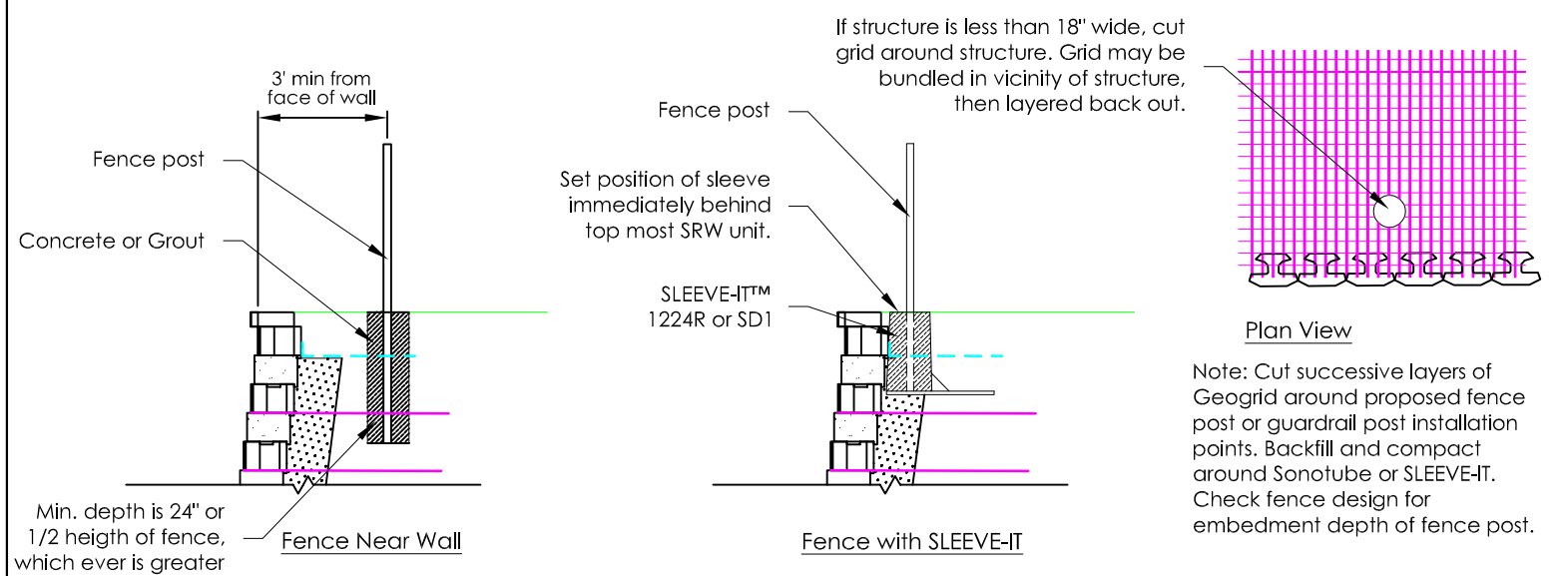

This drawing is furnished for preliminary design purposes only, and should not be used for final design drawings or construction drawings without the certification of a professional engineer registered in the state in which the wall will be constructed. These drawings are "typical" and may be amended or revised by the SRW engineer based on project site conditions and purposes.

No.	Date.	Revision.	By.

PREPARED BY:

Legend	
	Leveling Pad
	Drainage Rock
	Geogrid
	Finish Grade
	Filter Fabric

Project Name: _____
 Project Location: _____
 Drawing Description: **Typical Details**
 Prepared For: _____
 Drawn By: _____ Checked By: _____
 Sheet: _____
 Date: _____
 Project Number: _____

Water Application

Rockwood Classic™

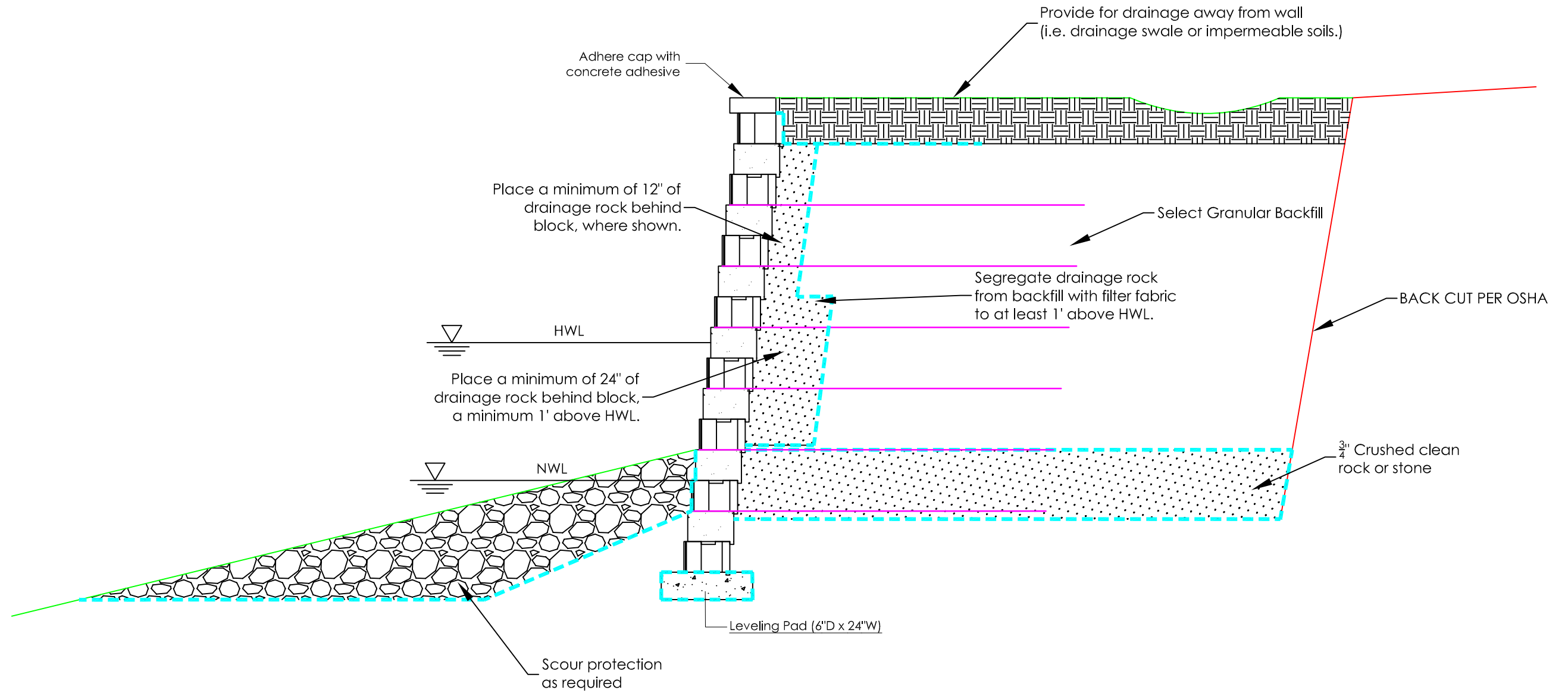

Not to Scale

This drawing is furnished for preliminary design purposes only, and should not be used for final design drawings or construction drawings without the certification of a professional engineer registered in the state in which the wall will be constructed. These drawings are "typical" and may be amended or revised by the SRW engineer based on project site conditions and purposes.

No.	Date.	Revision.	By.

PREPARED BY:

Legend	
	Leveling Pad
	Drainage Rock
	Geogrid
	Finish Grade
	Filter Fabric

Project Name:	
Project Location:	
Drawing Description:	Water Application

Prepared For:	
Drawn By:	
Checked By:	
Sheet:	
Date:	
Project Number:	

Typical Tiered Cross Section

Rockwood Classic™

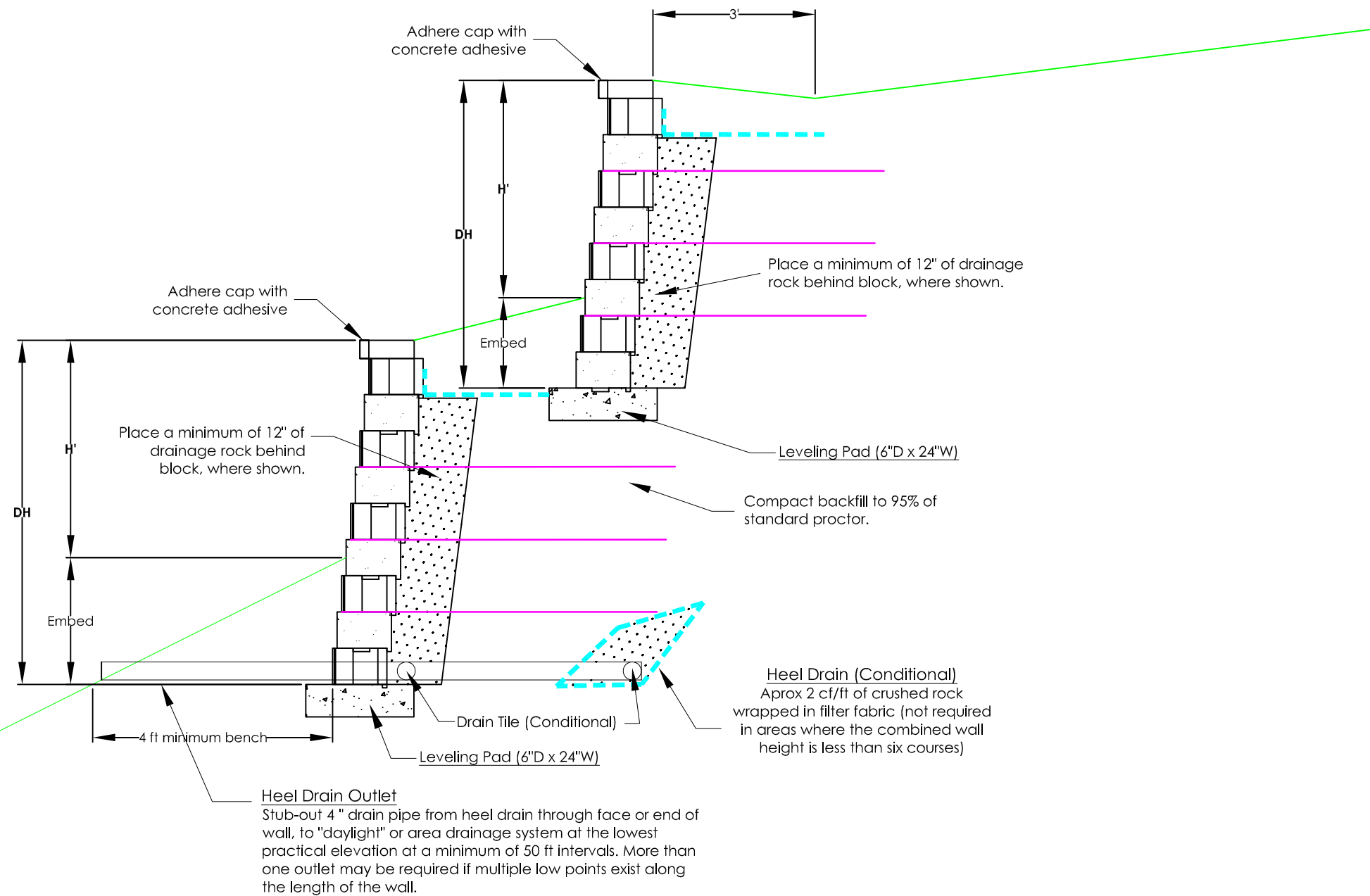

NCMA Minimum Embedment	
Slope in front of wall	Minimum H_{emb} to top of Leveling pad
Horizontal (Walls)	$H'/20$
Horizontal (Abutments)	$H'/10$
3H:1V	$H'/10$
2H:1V	$H'/7$
Minimum embedment	6 in

Note: H' is the exposed height of the SRW. The bottom of the wall should not be above the finish grade elevation 4ft in front of the wall

Not to Scale

This drawing is furnished for preliminary design purposes only, and should not be used for final design drawings or construction drawings without the certification of a professional engineer registered in the state in which the wall will be constructed. These drawings are "typical" and may be amended or revised by the SRW engineer based on project site conditions and purposes.

No.	Date.	Revision.	By.

PREPARED BY:

Legend	
	Leveling Pad
	Drainage Rock
	Geogrid
	Finish Grade
	Filter Fabric

Project Name: _____
 Project Location: _____
 Drawing Description: **Typical Tierd Cross Section**

Prepared For: _____
 Drawn By: _____
 Checked By: _____
 Sheet: _____
 Date: _____
 Project Number: _____

Typical Cross Section

Rockwood Classic™

NCMA Minimum Embedment	
Slope in front of wall	Minimum H_{emb} to top of Leveling pad
Horizontal (Walls)	$H/20$
Horizontal (Abutments)	$H/10$
3H:1V	$H/10$
2H:1V	$H/7$
Minimum embedment	6 in

Note: H' is the exposed height of the SRW. The bottom of the wall should not be above the finish grade elevation 4ft in front of the wall

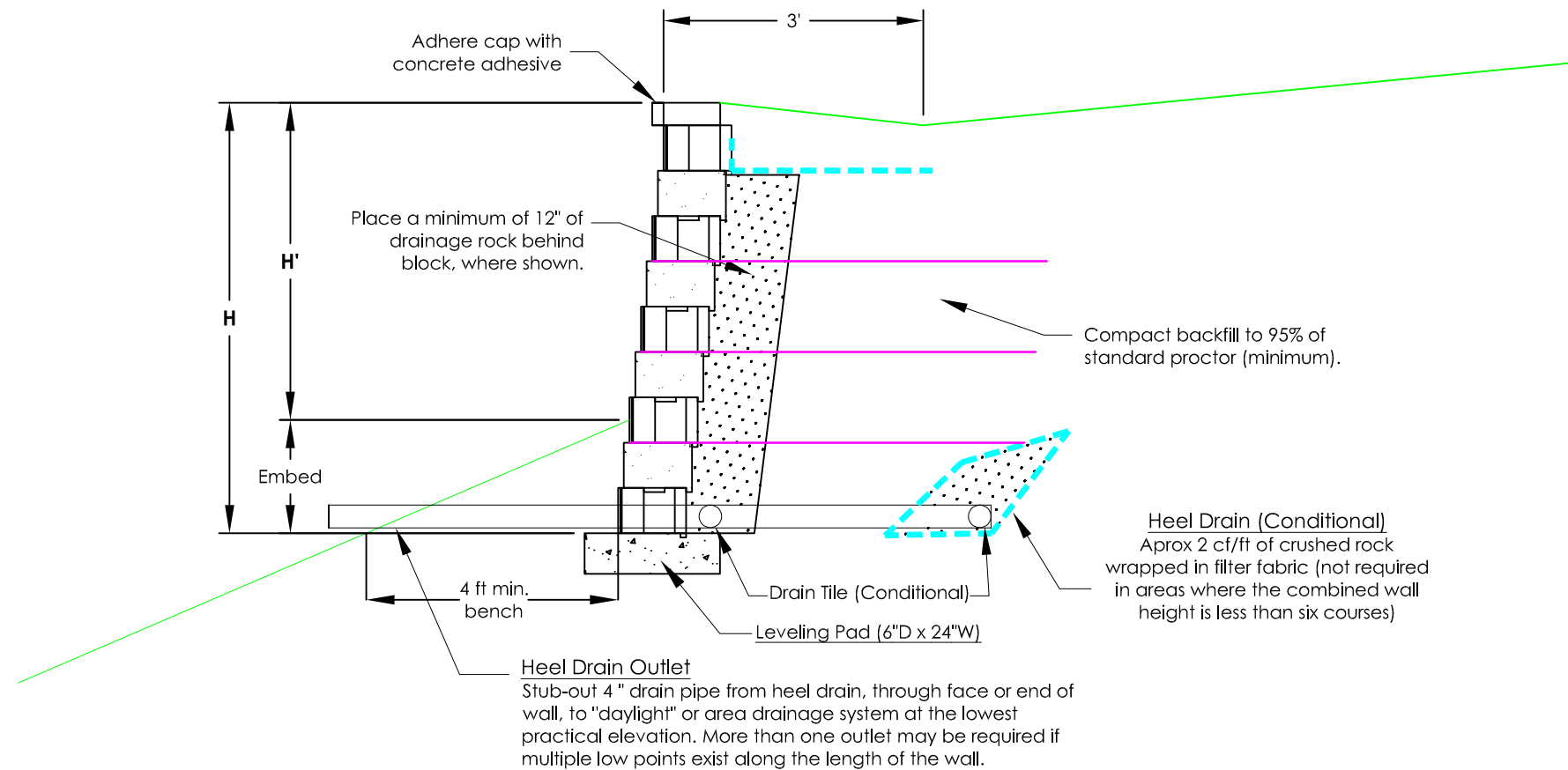

Not to Scale

This drawing is furnished for preliminary design purposes only, and should not be used for final design drawings or construction drawings without the certification of a professional engineer registered in the state in which the wall will be constructed. These drawings are "typical" and may be amended or revised by the SRW engineer based on project site conditions and purposes.

No.	Date.	Revision.	By.

PREPARED BY:

Legend	
	Leveling Pad
	Drainage Rock
	Geogrid
	Finish Grade
	Filter Fabric

Project Name:	
Project Location:	
Drawing Description:	Typical Cross Section

Prepared For:	
Drawn By:	
Checked By:	
Sheet:	
Date:	
Project Number:	

Leveling Pad Detail

Rockwood Classic™

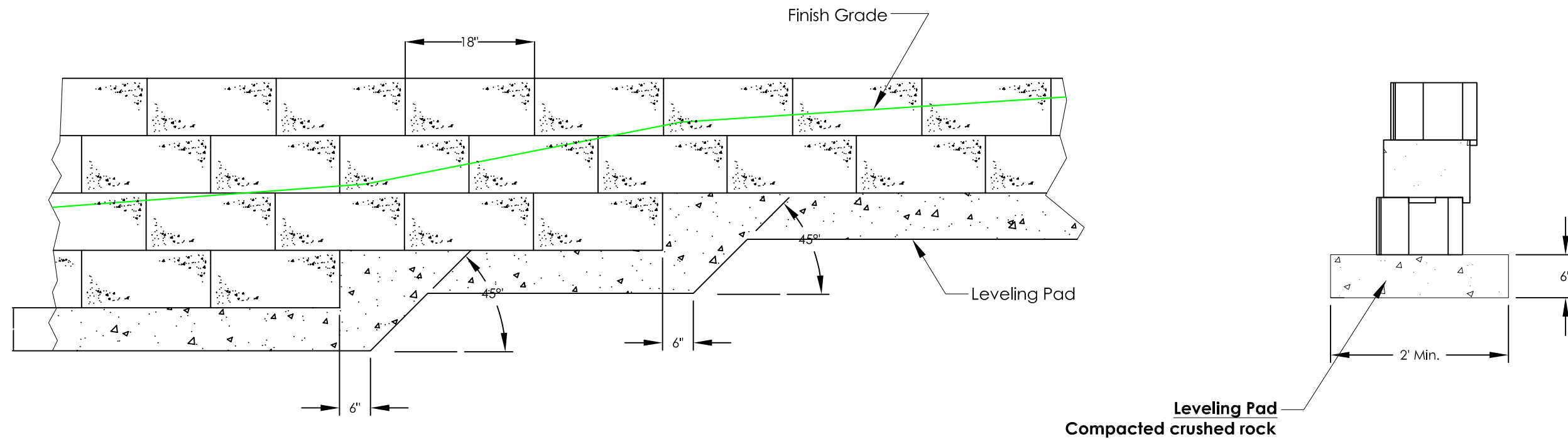

Not to Scale

This drawing is furnished for preliminary design purposes only, and should not be used for final design drawings or construction drawings without the certification of a professional engineer registered in the state in which the wall will be constructed. These drawings are "typical" and may be amended or revised by the SRW engineer based on project site conditions and purposes.

No.	Date.	Revision.	By.

PREPARED BY:

ROCKWOOD
RETAINING WALLS
A better way.

Legend	
	Leveling Pad
	Drainage Rock
	Geogrid
	Finish Grade
	Filter Fabric

Project Name:	Prepared For:
Project Location:	Drawn By: Checked By:
Drawing Description:	Sheet:
Leveling Pad Step Detail	Date:
	Project Number:

Abutment Detail

Rockwood Classic™

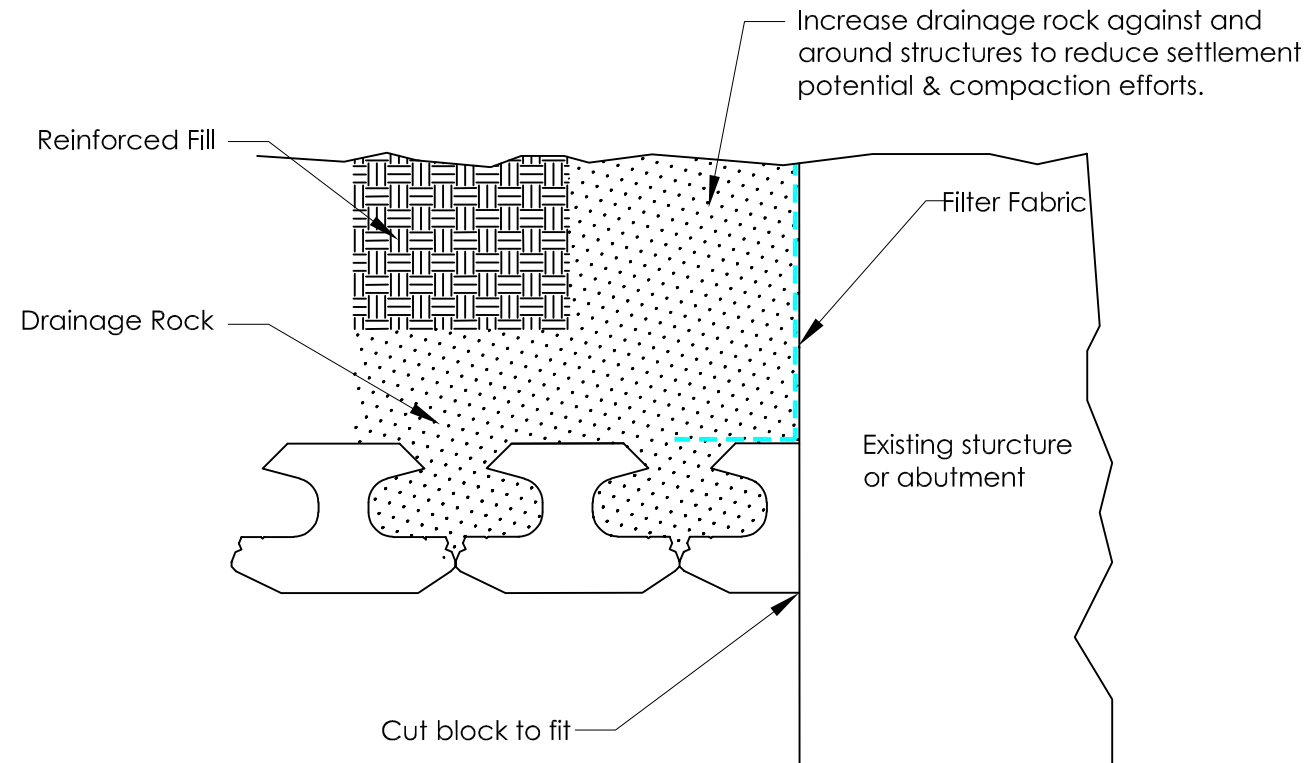

Not to Scale

This drawing is furnished for preliminary design purposes only, and should not be used for final design drawings or construction drawings without the certification of a professional engineer registered in the state in which the wall will be constructed. These drawings are "typical" and may be amended or revised by the SRW engineer based on project site conditions and purposes.

No.	Date.	Revision.	By.

PREPARED BY:

Legend	
	Leveling Pad
	Drainage Rock
	Geogrid
	Finish Grade
	Filter Fabric

Project Name:	
Project Location:	
Drawing Description:	Wall Abutment Detail

Prepared For:	
Drawn By:	
Checked By:	
Sheet:	
Date:	
Project Number:	